



**EU-SCORES**  
European Scalable Offshore Renewable Energy Sources

# European Scalable Offshore Renewable Energy Source (EU-SCORES)

D6.9 Report on the energy system transition relevance of  
offshore energy for Ireland

December 2025

Delivery Date	December 2025
Dissemination Level	Public
Status	Final Version
Version	1.0
Keywords	Offshore energy systems; wave energy; energy transition

## Disclaimer

This deliverable reflects only the author's views, and the Agency is not responsible for any use that may be made of the information contained therein.

## Document information

<b>Grant Agreement Number</b>	101036457
<b>Project Acronym</b>	EU-SCORES
<b>Work Package</b>	6
<b>Related Task(s)</b>	6.5
<b>Deliverable</b>	6.9
<b>Title</b>	Report on the energy system transition relevance of offshore energy for Ireland
<b>Author(s)</b>	Yousef Pourjamal, Dmitrii Bogdanov, Christian Breyer
<b>File name</b>	D6.9 Report on the energy system transition relevance of offshore energy for Ireland

## Revision history

<b>Revision</b>	<b>Date</b>	<b>Description</b>	<b>Reviewer</b>
1	24/11/2025	Task partners revision	Yousef Pourjamal, Dmitrii Bogdanov, Christian Breyer
2	09/12/2025	Consortium revision	EU-SCORES consortium
3	29/12/2025	Final revision for submission	Christian Breyer, Sarah Kluge



# Contents

Disclaimer.....	2
Document information .....	2
Revision history.....	2
Contents .....	3
0. Executive summary.....	7
1. Introduction .....	10
2. Methodological approach.....	14
2.1. Methods for energy system modelling.....	14
2.2. Regional structure of Ireland and the UK for energy system modelling .....	16
2.3. Scenarios for energy system modelling .....	17
3. Results.....	20
3.1. Final energy demand.....	20
3.2. Primary energy demand .....	22
3.3. Electricity supply .....	24
3.4. Heat supply .....	38
3.5. Transport, industry, and e-fuels.....	48
3.6. Sector coupling and flexibility in the energy system .....	54
3.7. Energy system cost and emissions .....	57
4. Complementary impacts .....	68
4.1. The role of ocean energy in achieving Ireland and the UK's energy targets .....	68
4.2. The role of technological diversity in achieving Ireland and the UK's energy targets.....	69
5. Summary and key messages.....	72
6. References .....	75



## Abbreviations

BNL	Benelux region
BPS	Best Policy Scenario
BPS_favourVPV	Best Policy Scenario with vertical PV
BPS_favourOE	Best Policy Scenario with high ORE
BPS_lowPV	Best Policy Scenario with low share of PV
BPS_noBPV	Best Policy Scenario with no bifacial PV
BPS_2040	Best Policies Scenario with carbon neutrality reached by 2040
BPV	Bifacial PV
Capex	Capital expenditures
CO <sub>2</sub>	Carbon dioxide
EC	European Commission
EU	European Union
FED	Final energy demand
FLh	Full load hours
FTL fuels	Fisher-Tropsch Liquids fuels
GHG	Greenhouse gas
GHI	Global horizontal irradiation
HDV	Heavy duty vehicle
IEA	International Energy Agency
LCOC	Levelised cost of curtailment
LCOE	Levelised cost of electricity



This project has received funding from the Europeans Union's Horizon 2020 research & innovation programme under grant agreement number 101036457.

LCOFE	Levelised cost of final energy and non-energy use
LCOH	Levelised cost of heat
LCOS	Levelised cost of storage
LDV	Light duty vehicle
LUT-ESTM	LUT Energy System Transition Model
MDV	Medium duty vehicle
NDC	Nationally Determined Contribution
NOAA	National Oceanic and Atmospheric Administration
Opex	Operational expenditures
ORE	Offshore renewable energy
OSPV	Floating offshore solar photovoltaics
O&M	Operation and maintenance
PED	Primary energy demand
PV	Photovoltaics
RE	Renewable energy
SDGs	Sustainable Development Goals
SMR	Steam methane reforming
TES	Thermal energy storage
TES DH	District heating thermal energy storage
TES HT	High temperature thermal energy storage
TPED	Total primary energy demand
TTW	Tank-to-wheel



UK	United Kingdom
UN	United Nations
WMO	World Meteorological Organization
WACC	Weighted average cost of capital



This project has received funding from the European Union's Horizon 2020 research & innovation programme under grant agreement number 101036457.

## 0. Executive summary

Offshore renewable energy (ORE) plays a pivotal role in the transition to a carbon-neutral energy system in the European Union (EU). Accurately capturing the contribution of offshore wind power, wave power, and floating offshore solar photovoltaics (OSPV) in the design of Europe's future energy systems is becoming increasingly important when defining energy transition (ET) scenarios with greater precision and to unlock the full potential of renewable energy (RE) resources. These technologies are no longer viewed as peripheral options but as central building blocks for a resilient, integrated, and defossilised energy system, capable of meeting ambitious long-term climate objectives.

The purpose of this report is to evaluate the significance of ORE within the **Republic of Ireland** (in the following called **Ireland**) energy system transition through the application of high-resolution modelling of the interconnected energy system of **Ireland and the United Kingdom (UK)**. Therefore, the integrated energy system of both countries is investigated throughout the report to extract accurate insights for **Ireland**. The study is designed to support the EU's wider ET by offering a clear and evidence-based vision of how different ORE technologies will shape the ET in both **Ireland and the UK**. By employing a multi-node modelling approach and using high-resolution spatial and temporal operational data, the report investigates in detail how offshore wind power, wave power, and OSPV interact with onshore RE supply, alter overall system costs, place new demands on transmission and distribution grids, and contribute to long-term defossilisation pathways in the region. The analysis is conducted in the broader European context, with a horizon to 2050, ensuring that the results are directly relevant to continental-scale policy and system planning.

This report directly aligns with the priorities of the European Green Deal, which emphasises the rapid and sustained growth of RE in the EU's total energy supply. The findings also reinforce the strategic importance of the region as a testbed and leader in ORE integration, highlighting how effective deployment of ORE can accelerate progress towards EU climate neutrality, strengthen regional cooperation, and ensure that the transition delivers environmental, economic, and societal benefits across multiple scales.

This study expands the LUT Energy System Transition Model (LUT-ESTM) to incorporate ORE technologies, i.e., offshore wind power, wave power, and OSPV, to assess their role in achieving the European Green Deal targets. Leveraging high-resolution spatial (0.45°) and temporal (hourly) data, and validated techno-economic input from the EU-SCORES project, the model enables a comprehensive analysis of ORE resource potentials across European regions. Six scenarios are developed, aligned with, above, and below the ambition of the Green Deal, to evaluate the systemic impact of ORE technologies and the broad diversity of PV technologies to better assess ORE opportunities. The results provide insights into system operation, overall cost implications, and greenhouse gas (GHG) emission reductions, highlighting the relative importance of each offshore technology under various transition pathways.



The ET scenarios for the energy system were modelled using LUT-ESTM, a linear optimisation tool designed to create cost-optimised scenarios for the full energy-industry system. It features hourly resolution over a full year, a geographical multi-node structure, and methodologies for dispatch and investment optimisation. The ET is explored through six diverse scenarios: the reference Best Policy Scenario (BPS), aligned with the European Green Deal and the European Commission's (EC) ORE growth targets, two scenarios examining the effects of expanded ORE technologies including OSPV, a scenario with a lower share of onshore PV systems, increased share of vertical bifacial PV systems, a scenario with restricted bifacial PV (BPV) systems, and an accelerated pathway to carbon neutrality by 2040. The PV-related scenarios shall improve the insights for ORE opportunities.

The key findings of this report indicate that the scenario prioritising offshore wind power and OSPV results in a modest increase in overall system costs compared with the baseline scenario. Nevertheless, this favoured ocean energy (OE) pathway is less costly than an energy system with accelerated ET or limited solar PV deployment in terms of both annualised system cost or levelised cost of electricity (LCOE), suggesting that ORE technologies can be deployed at scale without imposing an excessive economic burden. More importantly, the favoured OE scenario delivers substantial system-wide benefits by enhancing stability and diversity and reducing reliance on large-scale electricity storage and hydrogen-based balancing. At the same time, targeted grid reinforcement elevates the importance of transmission capacity, enabling electricity generated offshore to be transmitted effectively to the shore and ensuring that landlocked regions also benefit from the introduction of OE.

Furthermore, the analysis shows that incorporating offshore wind power, OSPV, and wave power into the energy systems of **Ireland and the UK** does not lead to significant increases in total system costs compared to scenarios featuring lower shares of ORE technologies. Rather, these systems offer notable advantages in terms of system diversity and resilience. The interplay between OE and OSPV therefore emerges as critical, with OE improving system flexibility and resilience, and OSPV decisively contributing to lowering costs and maintaining economic efficiency. Together, these findings highlight the need for a carefully balanced portfolio of RE technologies to ensure a robust, affordable, and sustainable ET.

Shifting the energy system towards higher shares of RE is a crucial strategy to cut GHG emissions and avoid irreversible damage to the planet. Such a transition delivers benefits that extend well beyond the reduction of fossil fuel dependence and the mitigation of environmental impacts, with ORE technologies assuming a particularly central role. Offshore wind power, wave power, and OSPV provide a vast and still largely untapped resource potential, combined with favourable and often predictable generation profiles that complement onshore RE and help stabilise the overall system output. In some regions with high population density and consequently high energy demand and low area availability for onshore RE, ORE technology use is necessary to satisfy the energy demand in a sustainable energy system. Their deployment also reduces exposure to volatile fossil fuel



markets, strengthens long-term energy security, and improves resilience in the face of increasingly extreme weather events linked to climate change.

In addition to their technical contribution, ORE deployment stimulates regional economies through investment in coastal infrastructure, port facilities, and supply chains, while supporting innovation in grid integration, storage, and digital monitoring solutions. **Ireland**, with extensive maritime zones and a strong natural resource base, is particularly well positioned to harness these advantages. By scaling up ORE in parallel with onshore RE, the region of **Ireland and the UK** can build a more balanced and diversified generation mix, reinforcing both flexibility and reliability. Taken together, these advances make ORE a decisive enabler of a resilient, balanced, and fully defossilised energy-industry system that both addresses environmental imperatives and underpins economic growth and societal well-being across the region.

This report examines the impact of ORE technologies across all components of the energy system in detail, considering their operation, integration, and influence on overall system costs, as well as their potential to contribute to GHG emission reduction targets. Particular attention is given to the dynamic nature of these impacts, highlighting how the role of ORE evolves throughout the transition period. The analysis underscores that while the early stages may be shaped by investment requirements and infrastructure adjustments, the longer-term benefits become increasingly evident through lower operational costs, enhanced system flexibility, and significant progress towards defossilisation objectives.



## 1. Introduction

The impacts of climate change are leading to an increase in global average surface temperatures. The global average surface temperature according to the National Oceanic and Atmospheric Administration (NOAA) [1] reached 1.29°C above the 20<sup>th</sup> century average and 1.46°C above pre-industrial average. According to the World Meteorological Organization (WMO) [2] the global average temperature was 1.55°C in 2024 above the 1850-1900 average. The average air temperature in Europe during the same period increased even faster to 2.88-3.01°C [3] indicating that Europe is warming twice as fast as the global average [4]. This unfavourable change in global and European temperatures indicates a significant increase in extreme weather events and may lead to climate hazards [3]. Climate change, and in particular the average increase in air temperature is primarily caused by anthropogenic emissions of greenhouse gases (GHG) and in particular carbon dioxide (CO<sub>2</sub>) emissions, the main source of which is the use of fossil fuels in the energy system. A transition from fossil fuels to low-carbon energy sources such as renewable energy (RE) is a necessary climate change mitigation strategy to prevent the worst impacts of climate change [5].

The long-term vision presented by the European Commission (EC) in the European Green Deal [6] provides possible scenarios for Europe's transition to a climate-neutral economy by 2050, in line with the goals of the Paris Agreement [7]. Among the key strategic objectives of the European Union (EU) are the reduction of GHG emissions by at least 55% by 2030 and the achievement of carbon neutrality by mid-century [8]. In March 2023, the EU stepped up its efforts to accelerate the deployment of RE sources, setting a target to increase their share in total energy consumption to 42.5% by 2030, with an additional target of 45% [9]. To achieve these objectives, the EU and its member states play a leading role in the deployment of RE technologies, including offshore RE (ORE). In particular, technologies such as floating offshore solar photovoltaics (OSPV) are seen as a promising element of future energy systems in European countries [10], especially in regions with high ORE potential, such as the **Republic of Ireland** (in the following called **Ireland**) and the **UK**. The growing share of ORE contributes to the resilience, security, and flexibility of the European energy system.

The adoption of a more sustainable energy system based on clean technologies are key indicators of a sustainable energy future. The transition towards a low-carbon energy system is already progressing in numerous countries. According to studies [11–14], this process both contributes significantly to climate change mitigation and generates considerable economic advantages. Many countries are already progressing towards low-carbon energy, and the EU, particularly **Ireland** [15–17] and the **UK** [18,19] with its favourable conditions for ORE.

Solar PV, one of the main and the fastest-growing RE technology in the world [20,21], will play a significant role in achieving the EU's climate-neutrality goal by 2050 [22]. It is the most cost-effective electricity source, with the capability to meet all final energy demand (FED) through sector coupling and power-to-X (PtX) technologies [23–25]. Together with onshore wind power, solar PV has the potential



to become the main energy source across Europe in the near future [22,26,27]. However, to support flexibility and reliability of the system, and to supply energy where and when solar PV and wind power are limited, ORE becomes an important part of the future energy mix [19,28]. ORE in general delivers a more stable electricity generation profile and have relatively high-capacity factors [29,30]. Moreover, in **Ireland and the UK**, wave power, offshore wind power, and OSPV could provide power to the land, where energy demand is high. In addition, due to relatively stable electricity generation profiles, ORE could potentially reduce the need for energy storage in future energy systems and stand on par with onshore RE technologies [31].

Europe holds a leading position in the offshore wind power industry [32]. The existing offshore wind power capacity in Europe can cover the region's electricity needs, with demand projected to rise steadily in the years ahead. By 2025, Europe had around 37 GW of installed offshore wind power capacity connected to the grid [33]. Thereof, 2.6 GW was added in 2024, marking a 28% decrease compared to the 3.6 GW installed in 2023 [34,35]. **Ireland's** offshore wind power capacity has stagnated at 25.2 MW, which has been unchanged since 2020. For the UK, the capacity has reached around 15.9 GW with a 61% increase from 2020 [33]. Meeting the EU's climate targets will require a significant acceleration in the pace of installation and, as a result, an increase in investment in offshore wind power projects. According to targets set by the EC [6], to reach climate neutrality by 2050, the offshore wind power capacity is expected to reach 160 GW by 2030 and 450 GW in 2050, thereof 212 GW in the North Sea, 85 GW in the Atlantic Ocean (including the Irish Sea), 83 GW in the Baltic Sea, and 70 GW in the Mediterranean and other Southern European waters [35]. The installed capacity figures for 2030 and 2050 provide the foundation for constructing offshore wind power scenarios applied in the ET modelling for **Ireland and the UK** in this report.

The **entire region** exhibits strong foundations for a transition to 100% renewable electricity, supported by exceptional wind resources, particularly offshore, and expanding solar PV deployment. In 2024, **Ireland's** gross electricity supply comprised 40% RE, dominated by wind power (33.2%) and with small shares of solar PV (2.1%) [36]. In the UK, RE accounted for 50.4% of generation, with wind power at 29.2% [37].

Resource quality metrics corroborate these ambitions: the Global Wind Atlas reports mean wind power density at 100 m hub height of 1202 W/m<sup>2</sup> for the windiest decile of areas of **Ireland**, and a **UK** range from 1044 W/m<sup>2</sup> (England) to 1731 W/m<sup>2</sup> (Scotland) [38]. For wave energy, the Irish Atlantic coast exhibits annual mean wave power flux between 53 and 76 kW/m. In **UK** waters, the Outer Hebrides have around 50 kW/m (with winter peaks near 130 kW/m), while the Pembrokeshire Demonstration Zone in the Celtic Sea is characterised around 19 kW/m [39]. ORE resources across the region are among Europe's strongest, and current policy pathways reflect these potentials. **Ireland** targets 5 GW of grid-connected offshore wind power by 2030 with an additional 2 GW in development for off-grid uses, rising to 20 GW by 2040 and 37 GW by 2050 [40]. In the UK, the Clean Power 2030 Action Plan sets an ambitious target of 43–50 GW of offshore



wind power by 2030 [41]. Additionally, according to the International Renewable Energy Agency (IRENA) renewables statistics 2025 report [33], **Ireland** accounts for approximately 25 MW capacity of offshore wind power, and the UK reaches 15.9 GW in 2024. With these figures, ORE can complement onshore solar PV and wind power and provide the energy system with additional generation needed to ensure a reliable energy supply.

Besides ORE, the solid solar resource potential has accelerated PV deployment in both **Ireland and the UK**. Across **Ireland**, long-term global horizontal irradiation (GHI) spans 803–1095 kWh/m<sup>2</sup>, with the highest values along the south and southeast coasts [42,43]. In the UK, representative GHI levels from the Global Solar Atlas indicate 901 kWh/m<sup>2</sup> yr at Belfast, 987 kWh/m<sup>2</sup> yr in central England, and 1009 kWh/m<sup>2</sup> yr at coastal sites in west Wales, illustrating the country's broadly suitable solar resource for utility-scale and rooftop PV alike [43]. As of 2024, **Ireland's** total solar PV capacity exceeded 1.34 GW<sub>AC</sub> (1.61 GW<sub>p</sub>) with this amount being 102 MW<sub>AC</sub> (122 MW<sub>p</sub>) in 2019 [33], highlighting its proactive energy policy. The UK, on the other hand, had an installed solar PV capacity of 13.3 GW<sub>AC</sub> (16 GW<sub>p</sub>) by the end of 2020 and increased this figure to 17.9 GW<sub>AC</sub> (21.5 GW<sub>p</sub>) by the end of 2024 [33].

**Ireland's** updated National Energy and Climate Plan (NECP) increased the 2030 overall RE share target to 43% and sits alongside climate action plan targets for 80% renewable electricity by 2030 and delivery of at least 5 GW offshore wind power by 2030 (with a further 2 GW for off-grid consumers), scaling to 20 GW by 2040 and 37 GW by 2050; **Ireland's** climate law also mandates a 51% economy-wide GHG reduction by 2030 compare to 2018 and climate neutrality by 2050 [44,45]. In the UK, the government has a legally binding net-zero 2050 target and aims for a fully decarbonised electricity system by 2035 (subject to security of supply), with the clean power 2030 action plan setting a 2030 capacity pathway that includes 43–50 GW of offshore wind power; the UK's Nationally Determined Contribution (NDC) commits to at least 68% GHG reduction by 2030 (vs 1990) and at least 81% by 2035, and unabated coal power ended in 2024 [41,46].

In recent years, the maturation of offshore wind power and advances in OSPV and wave power have made their combined deployment a practical option [30]. Co-locating wind power with wave power or OSPV in multi-source energy parks aims to enhance the sustainability of ORE technologies by using ocean resources more efficiently while simultaneously reducing overall costs through shared foundations, electrical infrastructure, grid connections, operations and maintenance, and port logistics.

Greater technological diversity across solar PV and ORE is making future RE systems more flexible, more sustainable, and more efficient than today [47,48]. In the **entire region**, solar resources are moderate but reliable [42,43], and advanced PV technologies offer clear advantages in the maritime environment. Additionally, research [47,49] indicates that single-axis tracking increases energy yield by 15–20% relative to fixed-tilted PV, whereas bifacial modules typically provide up to 10% more yield in most regions. In some specific conditions, however, higher bifacial gains may occasionally be achieved. This technology allows for more efficient land



use, higher generation density, and economic benefits, which is especially valuable in areas with limited space or high energy demand [50].

With roughly 40% of **Ireland's** population (1.9 million people) and about 36% of the UK population living within 5 km of the coast, demand is concentrated near the shore and close to substations and landfalls [51]. When OSPV is co-located with offshore wind and wave power in these coastal settings where it is typically installed, this combination contributes to a more balanced and stable RE mix, complementing the solar irradiation pattern and reducing seasonal variability [52]. This technological diversification enhances system reliability, lowers storage requirements and curtailment, and enables **Ireland and the UK** to tap their full RE potential onshore and offshore.

Combining PV technological diversity with ORE, including OSPV, leads to a more resilient, regionally optimised, and efficient system architecture [28]. The findings support a strategic shift towards greater technological diversity across ORE and onshore solar PV, positioning diversification as a key driver of a sustainable energy transition in **Ireland**, the **UK**, and across Europe.

This report evaluates the role of ORE technologies in the ET of **Ireland**, for which an integrated energy system investigation of **Ireland and the UK** is required due their strong system interconnection, using high-resolution regional energy system modelling and quantifying their contributions to GHG emissions reductions. It further examines how ORE integrates with onshore RE supply, affects system costs and network requirements, and shapes defossilisation pathways for the **entire region** within the broader European context through 2050.

Additionally, the report evaluates the techno-economic performance of alternative ET pathways for the **entire region**, emphasising the comparative advantages of deploying ORE technologies, OSPV, offshore wind power, and wave power, relative to a baseline Best Policy Scenario (BPS) that favours standard PV expansion.

This report also aims to demonstrate that diversifying PV technologies can raise the share of RE, lower system costs, and ease land-use pressure, thereby supporting a more sustainable and reliable ET strategy.



## 2. Methodological approach

### 2.1. Methods for energy system modelling

The energy transition scenarios of the European energy-industry system were performed with the LUT Energy System Transition Model (LUT-ESTM) [11,26] a linear optimisation tool. For the given financial and technical assumptions and scenario, the model defines a cost-optimised transition pathway for the entire energy-industry system. LUT-ESTM operates in hourly temporal and multi-node spatial resolution. For each 5-year step of the transition pathway, LUT-ESTM defines a cost-optimal energy system structure and hourly dispatch to reach a balance of supply and demand for all energy carriers for each hour of a given weather year. Power, heat, transport, and industry sectors, including desalination, are co-optimised to maximise synergy effects and reach maximum overall efficiency of the energy system. The model allows for the exploration of different energy transition pathways. With its wide range of over 150 energy technologies across various sectors and uses, including transitional technologies, it is ranked amongst the most sophisticated tools for the analysis of long-term energy transition pathways [26] and it is currently one of the most widely used tools for research on the transition towards highly RE systems [53,54]. For fuel supply, the model simulates the production of electricity-based e-fuels (gaseous and liquid) based both on green e-hydrogen and CO<sub>2</sub> from point source capture of sustainable CO<sub>2</sub> sources and direct air capture units, which are part of the power-to-X (PtX) concept [24] as an integral element of the arising Power-to-X Economy [55]. A description of how LUT-ESTM is designed in more detail, with all sectors integrated and the key equations involved can be found in Bogdanov et al. [26] and [11]. The output of the model is a transition path optimised for a given scenario definition, considering factors such as CO<sub>2</sub> emission targets, shares of conventional and RE sources, technology costs in different transition years, implementation costs, and GHG emissions. Figure 1 shows the basic architecture of LUT-ESTM. The simplified scheme of a sector-coupled energy system, as modelled with LUT-ESTM is shown in Figure 2 [11,26].

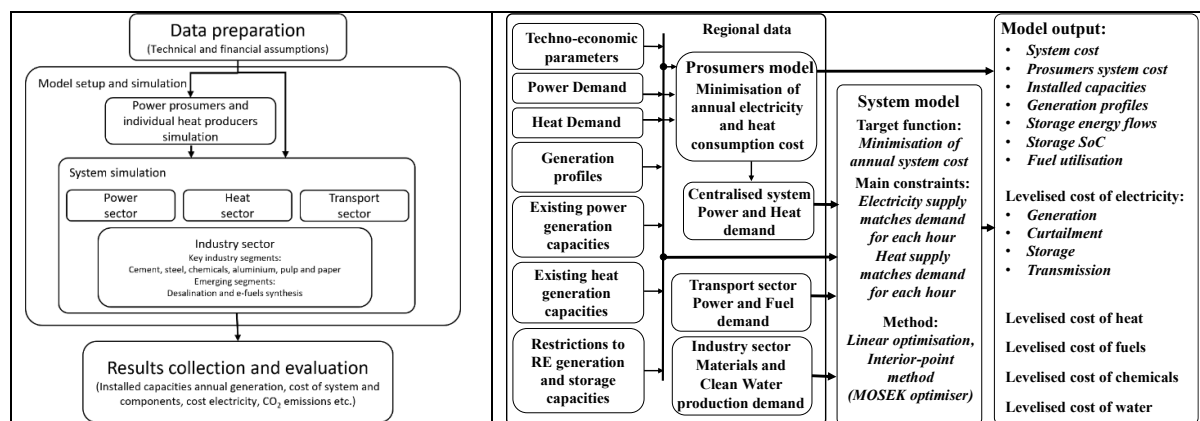

Figure 1 - Schematic representation of LUT-ESTM (left) and the model flowchart (right).



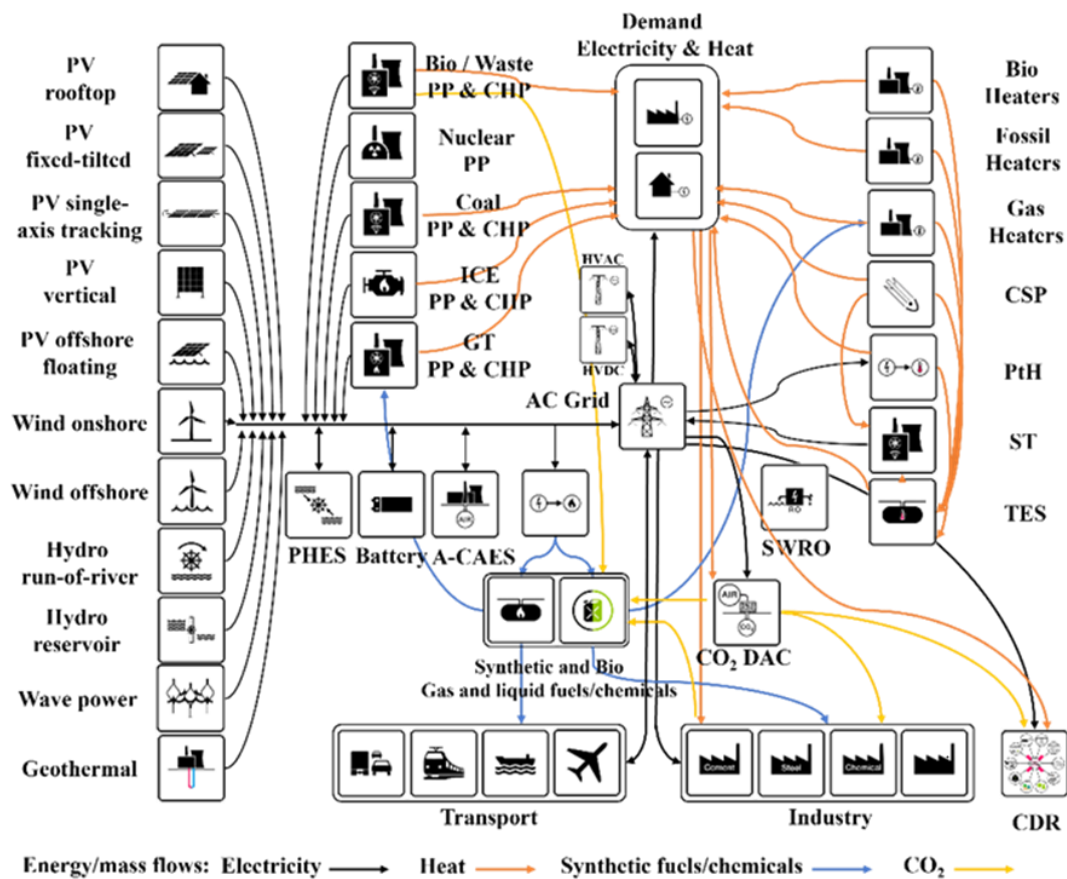

Figure 2 - LUT-ESTM integrated energy system structure scheme.

LUT-ESTM covers ORE technology, including offshore wind power, OSPV, and wave power based on respective energy potentials [29,30], and considered the electricity generation across the different technologies based on the installed capacities, and the respective energy yield following the applied scenarios. A diverse portfolio of generation and storage technologies, coupled with hourly resolution, facilitates the exploration of key insights into the optimal structure of future energy systems and the potential synergies among different generation and storage technologies. Moreover, the ability to model at an hourly resolution for an entire year can uncover crucial insights on RE technology operation. Grid connection capital expenditures (capex) are included in all power generation technologies, also for ORE. CO<sub>2</sub> emissions are priced at the point of emissions, such as for fossil fuel plants, industrial emitters, or transport vehicles.

The model target function is to minimise the total annualised cost of the entire energy system, comprised of annualised capex, operational expenditures (opex), fuel costs, GHG emission costs, and ramping costs of all system elements. Respective parameter assumptions were made about future technological development, the use of different technologies, economic development, cost changes, and changes in consumer behaviour.

The model guarantees that the energy demand for all sectors will be satisfied for all energy carriers and for each hour of a year. The inputs define electricity demand



for general application, heat consumption for space heating, domestic hot water, and industrial process heat demand, transportation services demand, and demand for key industrial products. The model considers both energy and feedstock requirements for industries including cement, steel, chemicals, pulp and paper, aluminium, and others [23]. A crucial part of the transition is to divert from the use of fossils as feedstock and source of energy, enabling the industry sector to rely entirely on renewable energy and feedstock. Transportation demand is derived across various modes, including road, rail, marine (with inland waterways and international transportation), and aviation (with domestic and international transportation), for both passenger and freight transportation. The road segment is further divided into categories such as light-duty vehicles (LDV), two- and three-wheelers (2W/3W), buses for passenger transport, and medium and heavy-duty vehicles (MDV and HDV) for freight transport. Demand in other transportation modes is estimated in passenger kilometres (p-km) for passengers and metric ton kilometres (t-km) for freight. Additional details regarding transportation demand, fuel shares, and energy requirements are provided by Khalili et al. [56]. The optimisation aims to minimise the total cost of the energy system.

A detailed overview of the methodology, along with the technical and financial assumptions that are considered in modelling the European power, heat, transport, and industry sectors, are available in Bogdanov et al. [26]. These are based on the detailed description of the model applied to the global power sector in Bogdanov et al. [57] and all energy sectors in Bogdanov et al. [11].

## 2.2. Regional structure of Ireland and the UK for energy system modelling

To explore interactions in the future energy system of **Ireland and the UK**, and reflecting their geographical affinities, the **entire region** is represented as a strongly interconnected electricity system. A multi-node set-up was employed, dividing the area into ten sub-regions. Table 1 lists these nodes alongside their corresponding administrative areas and the centre of consumption.

In order to achieve robust energy system analyses for **Ireland and the UK** in LUT-ESTM, the **entire region** is comprised of ten regions, with the power systems of the nodes being interconnected according to existing power grids. The region nodes follow the borders of autonomous communities: the Republic of **Ireland**, Northern Ireland, the Southwest and Southeast of England, East Midlands and West Midlands of England, Northwest of England, Northeast of England with Yorkshire and The Humber, Greater London, East of England, Scotland, and Wales (see Table 1 and Figure 3).

*Table 1. Description of the regional structure in the Ireland and the UK.*



Node name	Region	Centre of consumption	Area (km <sup>2</sup> )
IR	Republic of Ireland	Dublin	70,273
NIR	Northern Ireland	Belfast	13,874
E – S	England – Southwest, Southeast	Bristol	42,907
E – M	England – East Midlands, West Midlands	Birmingham	28,604
E – NW	England – Northwest	Manchester	14,105
E – NE	England – Northeast, Yorkshire and The Humber	Leeds	23,981
E – L	England – Greater London	London	1738
E – E	England – East	Norwich	19,108
SC	Scotland	Glasgow	79,272
W	Wales	Cardiff	20,735

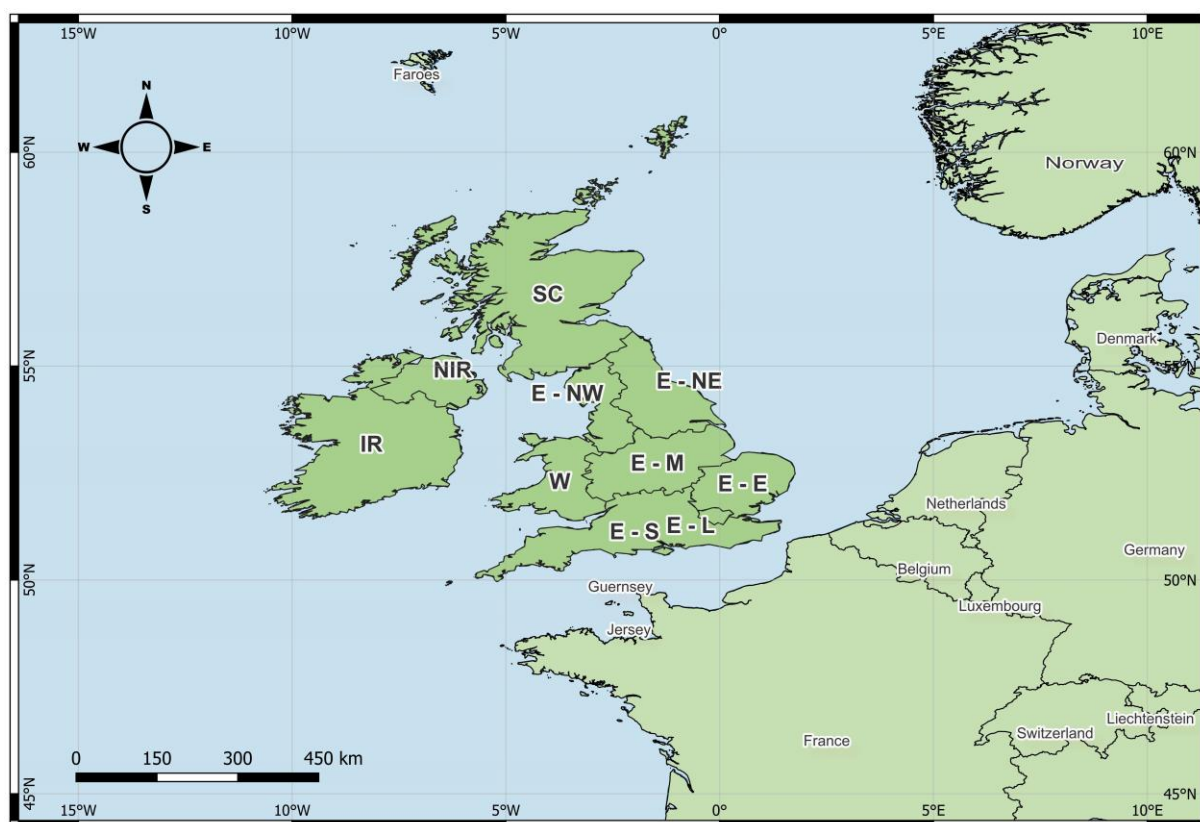

Figure 3 – Regional structure of the Ireland and the UK.

### 2.3. Scenarios for energy system modelling

The ET across the **entire region** is explored in six distinct scenarios with the following boundary parameters and conditions: The reference BPS sets the net-zero emissions target for 2050 according to the European Green Deal and follows the plans of the EC on ORE growth. The other scenario tests the impact of higher ambitions of offshore wind power, wave power growth, and the impact of OSPV introduction (favourOE). Three scenarios test the impact of different PV technology development variations, one with constrained PV potential (lowPV), limited introduction of bifacial PV (noBPV), and impact of vertical PV integration



This project has received funding from the Europeans Union's Horizon 2020 research & innovation programme under grant agreement number 101036457.

(favourVPV). The sixth scenario tests the impact of an accelerated transition with carbon neutrality reached by 2040 (BPS\_2040). In all scenarios, only existing or under construction nuclear power plants are considered and the lifetime of existing capacities cannot exceed 60 years.

**Best Policy Scenario (BPS):** In this scenario, the region's energy system is set on a reference pathway. The climate neutrality vision for **Ireland and the UK** [58,59] by 2050 is achieved, as GHG emissions reach net-zero by 2050 and are reduced by at least 55% in 2030 below 1990 levels. Investments in wave power are considered as a favoured capacity; however, build-out as part of a least-cost solution is allowed.

**Best Policy Scenario with favoured ORE (BPS\_favourOE):** This scenario follows the BPS targets, but with more ORE technologies installed. The targets for offshore wind power, wave power, and OSPV introduction are increased. The offshore wind power capacity is set to reach 15.4 GW across **Ireland and the UK** shores by 2030, 26.4 GW by 2040, and 38.1 GW by 2050. Similarly, the wave power capacity for the **entire region** is set to 4.4 GW by 2030, 18.1 GW by 2040, and 52.6 GW by 2050. The OSPV capacity are set to 3.1 GW in 2030, 13.2 GW by 2040, and 19.1 GW by 2050, following insights of upgrading offshore wind power with OSPV.

**Best Policy Scenario with vertical bifacial PV (BPS\_favourVPV):** This scenario follows the BPS targets, the offshore wind power and wave power capacity are on the same level as in the BPS; however, additional vertical bifacial PV capacities are introduced to trace which changes follow a high VPV share in the energy system. The VPV capacities for each 5-year interval are set to be 10% of the utility-scale PV capacity built in the BPS. The VPV capacity is set to 126.9 GW<sub>p</sub> in 2030, 663.3 GW<sub>p</sub> by 2040, and 1069.3 GW<sub>p</sub> by 2050.

**Best Policy Scenario with blocked bifacial PV (BPS\_noBPV):** This scenario follows the BPS targets, but bifacial PV technology is excluded from the energy mix. The focus is on evaluating the impact of this exclusion on overall PV penetration and the entire energy supply mix.

**Best Policy Scenario with reduced PV share (BPS\_lowPV):** This scenario reduces the share of solar PV in the overall energy supply mix compared to the standard BPS. The reduction share is set to 55% for 2030, 53% for 2035, and 50% for 2040-2050 years. It assesses the implications of relying less on solar PV and compensating with other RE sources, such as wind power, hydropower, or bioenergy, and in particular with ORE.

**Accelerated Best Policy Scenario 2040 (BPS\_2040):** This scenario accelerates the transition timeline, completely phasing out fossil fuels by 2040 instead of 2050. It explores the challenges and potential benefits of a faster transition, such as increased RE deployment, earlier emissions reductions, and technological advancements. In this scenario, the region's energy system is set on an accelerated ET pathway. Increased efforts to drive the RE share in FED to 56% in 2030 and 100% by 2040 is envisioned. This scenario enables energy-related CO<sub>2</sub> emissions reduction of at least 65% compared to 1990 levels, which is compatible with the



climate target of limiting temperature rise to below 1.5°C as defined in the Paris Agreement.

In this study, a particularly challenging case emerged in the London subregion, where the high population density and limited land surface area imposed severe constraints on the deployment of RE technologies. Within the modelling framework, each subregion was assigned energy demand across all sectors and local RE potential, with cross-border energy exchange permitted via interregional transmission lines and liquid green fuels. However, London's geographical characteristics, its dense urban structure, and limited direct access to coastal and offshore areas, restricted the installation of onshore RE and electrolyzers, thereby constraining the local e-hydrogen, e-methane, and e-ammonia production potential.

To overcome these limitations, a shared production and consumption pool of gaseous e-fuels was established between London, South England, and East England. This adjustment allowed for a more realistic representation of spatial interdependencies, acknowledging that large-scale industrial hydrogen and e-fuel production facilities are more feasibly located outside the urban core, where land and RE resources are more accessible. Nevertheless, even with this adjustment, the initial model runs indicated insufficient power transfer capacity to meet London's rising electricity demand. Consequently, the growth rate of the transmission grid connecting London to its neighbouring regions was increased from the standard 25% to 50% per five-year interval, enabling greater inflows of renewable electricity.

Furthermore, the ORE potential usage was expanded to 50% of its technical potential, allowing offshore resources, primarily offshore wind power, wave power, and OSPV, to provide a substantial share of the electricity required to balance London's demand. This modification ensured that the model captured the critical role of ORE in supplying densely populated, spatially constrained urban regions with clean electricity even for the geographically isolated regions. The results underscore that the strategic expansion of ORE, coupled with reinforced transmission capacity, is essential to enable self-sufficiency and defossilisation in metropolitan areas such as London. Such integration highlights the broader importance of ORE in achieving the UK's net-zero ambitions in cooperation with **Ireland's** energy system, both by increasing renewable electricity generation and supporting system flexibility and interregional energy interaction.



### 3. Results

Major changes will be required for the following ET from the current state of the electricity, heat, transport, and industry sectors to a sustainable and efficient integrated energy system. Progressing this transition would allow energy and raw material demand in **Ireland and the UK** to be largely met by locally available and sustainable resources. This study explores accelerated ET pathways to a carbon-neutral system transitioning to 100% RE over 2020–2050, testing multiple scenarios that explicitly consider the role of ORE technologies. This section reports trajectories for primary and final energy demand, installed electricity and heat capacities, and the resulting supply mix, and examines parallel transitions in the transport and industrial sectors. It concludes by comparing energy system costs and CO<sub>2</sub> emissions across all scenarios and highlighting regional differences. Results are presented for all ten regions in **Ireland and the UK** defined in Section 2, with comparative analysis and discussion of region-specific characteristics in key elements of the energy system.

#### 3.1. Final energy demand

The same energy and service demand assumptions, apart from the accelerated scenario, are used in all scenarios. Despite the expected growth in transport services and demand for industrial products, electrification and overall energy efficiency improvements lead to a significant reduction in FED over time. From 2020 to 2050, a clear and consistent downward trend in overall energy consumption is demonstrated. The five scenarios, except for the BPS\_2040, follow identical FED reduction pathways. The BPS\_2040 is the most ambitious scenario, assuming advanced policies across all sectors, including accelerated building retrofits, modal shifts in transport, and accelerated electrification in the transport and industry sector. Implementation of the appropriate policies is expected to lead to an even faster reduction in FED.

The FED for the **entire region** in 2025 is just over 1800 TWh. As shown in Figure 4, among sectors the transport sector has the highest share at 40% with 732 TWh. The second place is taken by the industry sector with a share of 14% and 257 TWh. By the end of the transition in all scenarios, due to the improvement in efficiency on the demand side in power, heat, transport, and industry, the FED decreases, from a total of 1816 TWh in 2025 to 1646 TWh in the BPS and to 1568 TWh in the BPS\_2040. The main change is the decrease in FED in the transport sector by 20% for the BPS from 730 TWh in 2025 to 583 TWh in 2050 and the increase in the industry sector by 22% from 257 TWh in 2025 to 313 TWh in 2050.

Naturally, the energy supply structure has no impact on FED trends. In the different scenarios such as the BPS, BPS\_favourOE, BPS\_noBPV, and BPS\_lowPV, the FED shows the same slight downward trend compared to 2020, with the transport sector demand in the **entire region** declining to 581 TWh in 2040 despite growth in the aviation segment, and the industry sector demand declining to 293 TWh. This is due to the high share of electric vehicles in transport, which leads to efficiency gains, as well as a shift towards greater use of electrified rail. Notably, in



This project has received funding from the European Union's Horizon 2020 research & innovation programme under grant agreement number 101036457.

the accelerated transition scenario, the total demand stabilises at a lower level than in the other scenarios, below 1600 TWh from 2040. Heat energy demand remains stable in all scenarios, and there is a slight decrease from 561 TWh to 502 TWh.

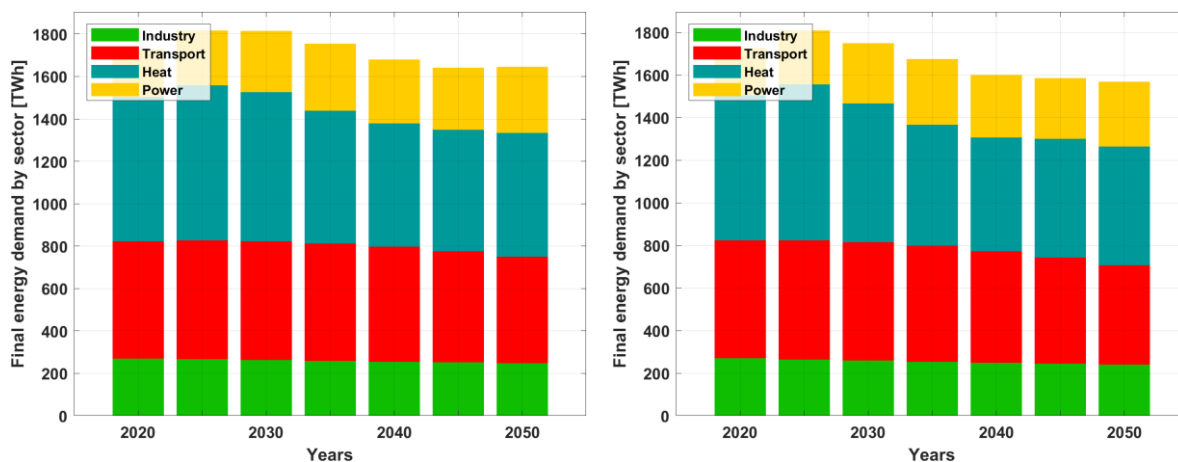

Figure 4 - Final energy demand by sector across the BPS (left) and the BPS\_2040 (right) scenarios during the ET in Ireland and the UK.

While the overall FED of the **entire region** decreases, the FED of **Ireland** reaches its minimum in 2045 and then slightly increases in 2050. The power sector demand steadily rises from 18.7 TWh in 2020 to 20.4 TWh by 2050, showing moderate growth (see Figure 5). The heat demand increases until 2035, reaching nearly 39.3 TWh, but then gradually declines to 37.8 TWh by 2050, driven by efficiency gains and electrification. The transport demand peaks early at 60.2 TWh in 2025 before sharply falling to around 45.6 TWh by 2050, reflecting a transition toward more efficient and electrified mobility. The industrial energy use consistently grows from 15.4 to around 26 TWh, indicating expanding production and electrification within the industry sector.

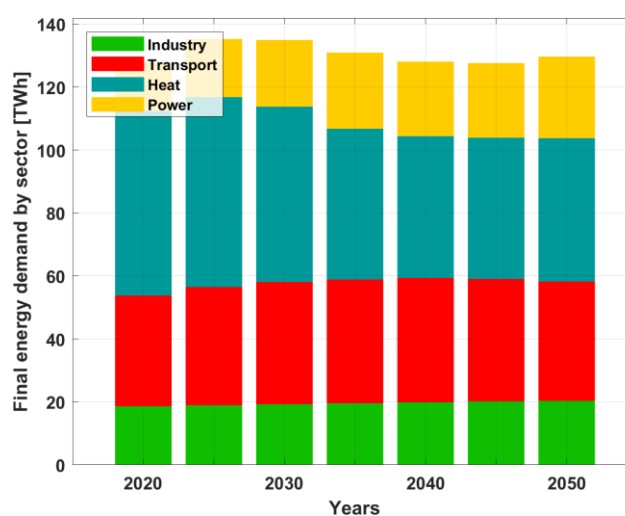

Figure 5 - Final energy demand by sector in the BPS\_favourOE in Ireland during the ET.



This project has received funding from the European Union's Horizon 2020 research & innovation programme under grant agreement number 101036457.

### 3.2. Primary energy demand

The evolution of the primary energy demand (PED) from 2020 to 2050 for the **entire region** in Figure 6 reflects a deep structural transformation toward a low-carbon, electricity-driven energy system. While total PED remains relatively stable, hovering between 2200 and 2670 TWh across all scenarios, the composition of energy supply dramatically changes. The data illustrate a near-complete shift away from fossil fuels and nuclear power towards RE, particularly renewable electricity, which becomes the dominant energy source by mid-century. The trajectory reflects not just a cleaner energy future but a more resilient and efficient one, built on electrification, RE dominance, and sustained policy commitment.

Renewable electricity growth for the **entire region** demonstrates the most remarkable growth trajectory. From only 107 TWh in 2020, it expands more than twentyfold to over 2200 TWh by 2050 in nearly all scenarios. This exponential increase underscores the accelerating pace of electrification and RE technology deployment. The BPS\_2040 scenario achieves the highest RE share. Even under more conservative pathways, renewable electricity maintains a commanding position, confirming its indispensability for energy security and decarbonisation.

In sharp contrast, fossil fuels undergo a rapid decline in the **entire region**. Fossil methane, the largest energy source in 2020 with 928 TWh, sharply diminishes, entirely disappearing by 2050 in every scenario. This reflects the substitution of gas-fired power and heating with RE-based systems and electrified processes. Fossil oil follows a similar pattern, dropping from 683 TWh to zero, driven primarily by transport electrification and e-fuel substitution. Coal, already a minor player in 2020, is fully phased out after 2030, marking the end of traditional carbon-intensive generation. Nuclear power also completely fades after 2040, signalling a full commitment to renewable electricity generation. The elimination of fossil feedstock demand by 2050 further reinforces the transition to circular systems, with supporting bioenergy-based solutions.

In the **entire region**, bioenergy stands out as the most stable element within the energy mix, remaining between 140 and 180 TWh throughout the projection period. Its persistence suggests that biomass will continue to play a complementary role, likely serving sectors where electrification is technically or economically challenging, such as aviation, maritime transport, or high-temperature industrial processes. Geothermal and solar energy (non-electric) remain comparatively minor, each contributing around 40 TWh.



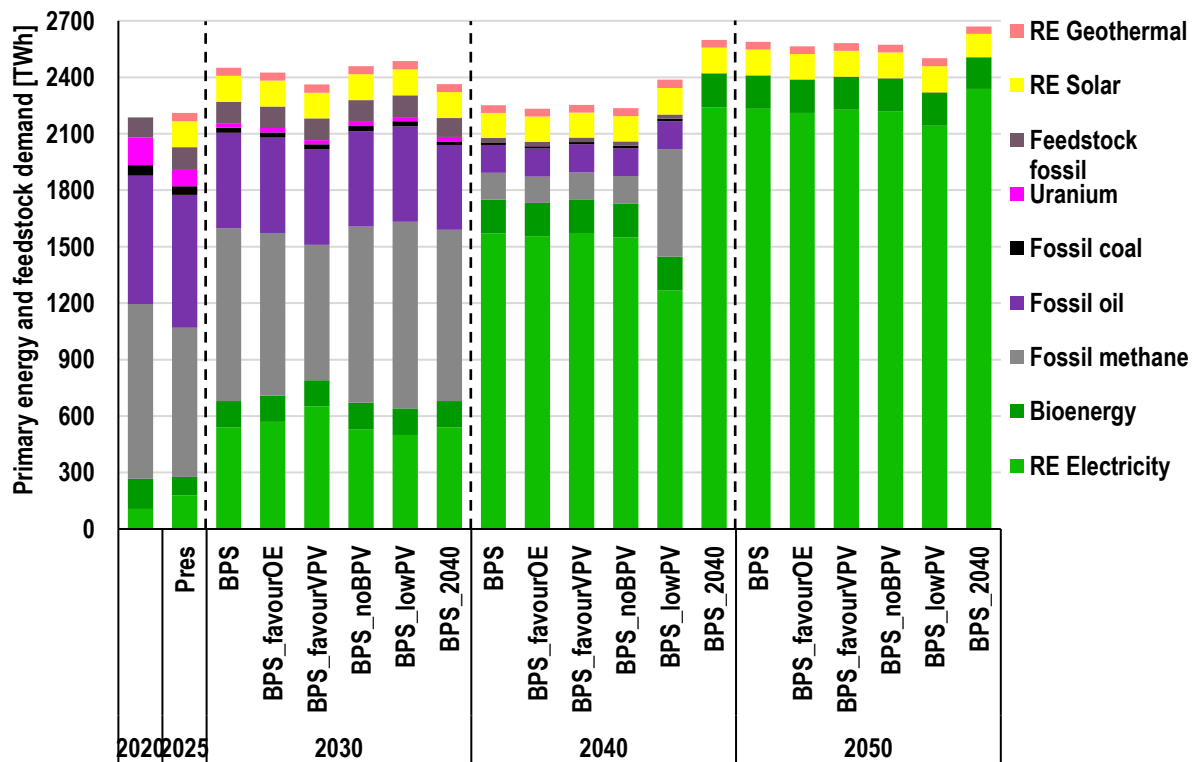

Figure 6 - Primary energy and feedstock demand in the entire region from 2020 to 2050 between all scenarios during the ET.

The steadiness of total PED despite deep structural changes highlights improvements in energy efficiency and the superior conversion efficiency of electrified systems. RE-based systems inherently require less primary energy to deliver the same services, as they avoid significant conversion losses typical of fossil combustion. This explains why the total energy demand does not rise substantially even as electricity consumption grows and new services, such as electric mobility, expand.

Accelerated or delayed implementation of ORE technologies does not have a substantial impact on the PED structure during the transition as ORE technologies mostly compete with onshore RE and the impact on defossilisation pace is limited.

When focusing **Ireland**, in the ORE favouring scenario (BPS\_favourOE), as Figure 7 indicates, renewable electricity grows sharply from 13 TWh in 2020 to 234 TWh by 2050, becoming the dominant source of energy. Bioenergy expands modestly, peaking at 16 TWh around 2035 before slightly declining. Fossil fuels experience a rapid and consistent decline, fossil methane falls from 73 TWh to zero, and oil drops from 58 TWh to zero by 2050. Coal almost fully disappears after 2035, and fossil feedstock use entirely ends by mid-century. In the BPS\_2040, the PED climbs to roughly 500 TWh in both 2040 and 2050, while in the BPS, BPS\_favourVPV, and BPS\_noBPV it stabilises at slightly over 300 TWh by 2050.



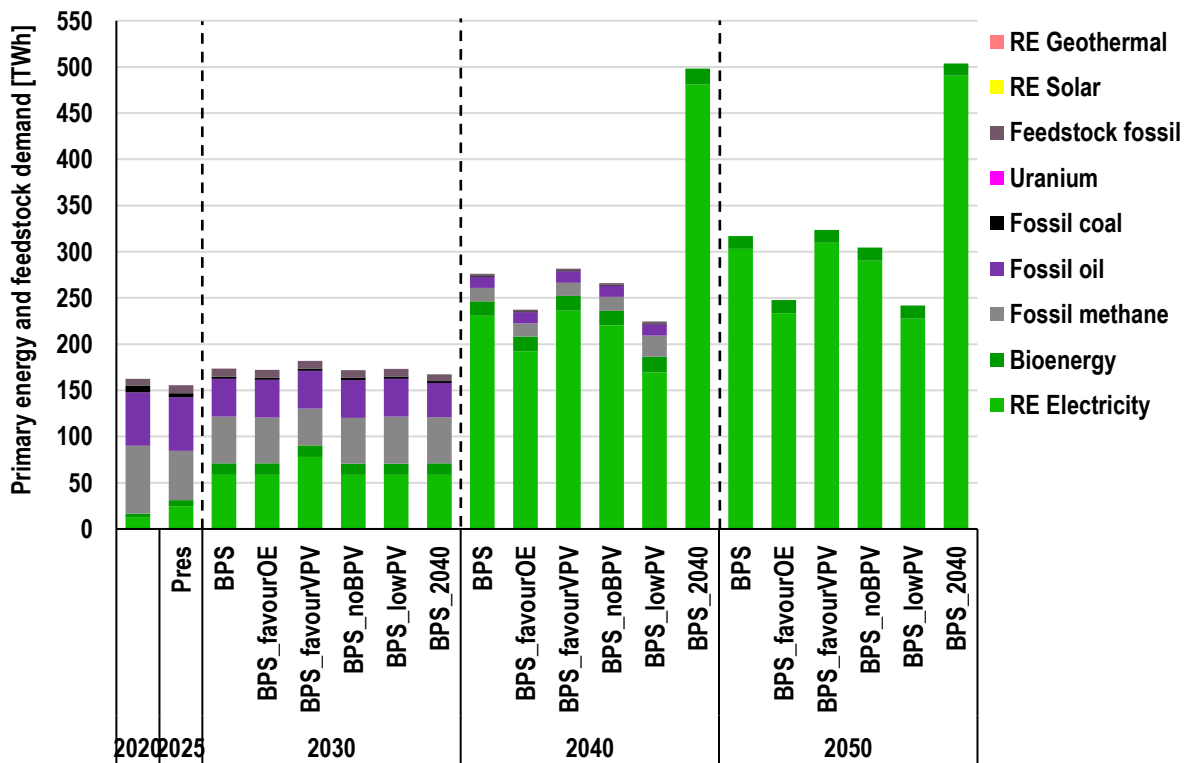

Figure 7 - Ireland primary energy and feedstock demand across all scenarios during the ET.

### 3.3. Electricity supply

As Figure 8 indicates, the evolution of installed electricity capacity for the **entire region** between 2020 and 2050 shows a decisive transition from a fossil fuel-based system to one dominated by RE, particularly solar PV and wind power. Total installed capacity dramatically expands from just over 110 GW in 2020 to well above 1500 GW by 2050 across all scenarios except for the BPS\_favourOE, which is 1327 GW, indicating both a massive scale-up of renewable electricity generation and the increasing electrification of end-use sectors. The overall pattern reflects technological progress as well as strong policy commitment to decarbonisation and energy security. By mid-century, the total installed capacity multiplies roughly fifteenfold, yet the system is almost entirely RE-based.

Solar PV emerges as the central pillar of future capacity expansion in the **entire region's** perspective. Onshore solar PV grows from a modest 16 GW in 2020 to over 1300 GW in the BPS and over 1400 GW in the progressive BPS\_2040. Even the more conservative or technology-restricted pathways show solar PV exceeding 1000 GW, confirming its role as the dominant electricity source. OSPV, still negligible today, appears only in a few scenarios, indicating that it remains an experimental complement rather than a core contributor. The remarkable rise of solar PV capacity highlights rapid cost reductions, high deployment flexibility, and its suitability for distributed generation across regions.



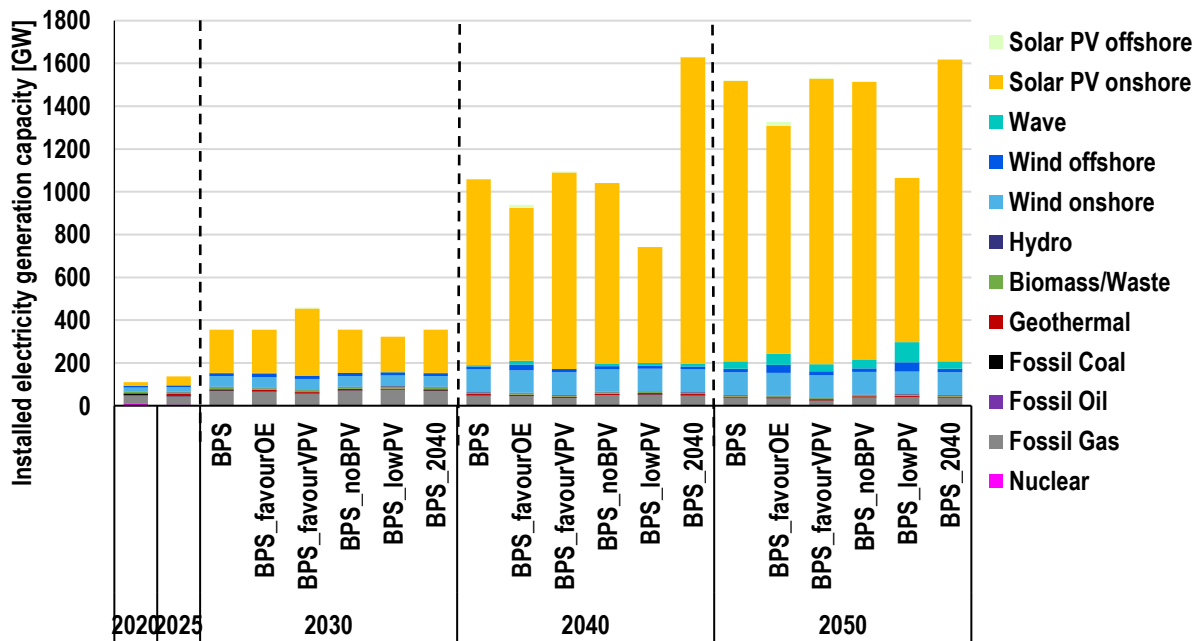

Figure 8 - Installed electricity generation capacities for all scenarios during the ET in the entire region.

Wind power, though growing at a slower pace in the **entire region**, remains an essential balancing component of the RE mix. Onshore wind power capacity grows almost five times by 2040 and reaches over 100 GW, and stabilises at that level, indicating early saturation of suitable land sites and grid limits. Offshore wind power starts from 9 GW in 2020 and, depending on the scenario, increases modestly to between 17 GW and 42 GW in the BPS\_lowPV by 2050, slightly higher than the ORE favouring scenario (BPS\_favourOE) to support less installation of solar PV. While its growth is less dramatic than solar PV, offshore wind power's steady presence reflects its value in providing more consistent generation and seasonal complementarity to solar PV output.

Hydropower and geothermal energy display near-static trends, maintaining around 3 GW and 5 GW respectively, throughout the transition for the **entire region**. Their constancy signals that these mature technologies have reached their practical capacity potential, though they continue to support system stability and baseload generation. Biomass and waste generation decline from 8 GW to about 4 GW by 2050, implying a gradual shift away from combustion-based RE as cleaner options expand. Emerging marine technologies, particularly wave power, exhibit notable though uncertain growth, potentially exceeding 90 GW in the BPS\_lowPV.

Fossil fuel and nuclear power capacities in the **entire region** experience a sharp and sustained contraction. Coal capacity, once 8 GW, falls virtually to zero by 2050. Oil remains insignificant, while gas capacity declines from 41 GW in 2020 to between 25 GW and 40 GW, serving as limited balancing capacity for flexibility and reliability rather than baseload generation. Nuclear power capacity disappears completely after 2030, underscoring a long-term commitment to RE dominance rather than nuclear power replacement. Nuclear power is recognised in all scenarios as being uncompetitive compared to low-cost renewable electricity and poses significant environmental and social risks, which are well documented in Europe and worldwide [60] and thus blocks new investments for overall societal



reasons [61,62]. Consequently, the model does not find new nuclear power capacities as part of a cost-optimal solution in any scenario. Existing construction sites and projects within permitting are considered to finally strand due to ever growing risks, financial uncertainties, and unresolved technical challenges.

Important to note, the ORE technology use is a necessary condition for the transition towards a sustainable self-sufficient energy system. The onshore RE potential is not sufficient to satisfy the energy demand mostly due to densely populated areas of England. The use of ORE allows the system to balance supply and demand in all parts of the region and, as the BPS\_favourOE shows, to substantially reduce land use as PV installed capacity decreases by 17%. Further reduction of PV capacities in the mix leads to a higher share of ORE in the capacities mix.

In a regional outlook, RE sources are evenly distributed across the countries, influencing the energy balance of different countries and regions. Electricity generation capacities are installed in the **entire region**, covering energy demand from the power, heat, transport, and industry sectors until 2050. Solar PV capacities are the largest source of electricity generation in all regions, while onshore and offshore wind power also represent a significant share, especially in the BPS\_lowPV scenario in Northern Ireland, Scotland, and the Northeast of England regions (see Figure 9). By 2050, the total electricity generation capacity for the **entire region** is estimated to reach 1524 GW in the BPS, 1335 GW in BPS\_favourOE, 1519 GW in BPS\_noBPV, and 1066 GW in BPS\_lowPV. For **Ireland**, specifically, the corresponding capacities are projected to be 191 GW, 122 GW, 182 GW, and 93 GW, respectively.

The installed wave power capacity strongly depends on the applied scenario. In the **entire region**, the wave power capacity reaches 34 GW, 53 GW, 34 GW, 43 GW, 95 GW, and 34 GW, in the BPS, BPS\_favourOE, BPS\_favourVPV, BPS\_noBPV, BPS\_lowPV, and the BPS\_2040, respectively, in 2050. Wave power is always part of the energy system, whereas it benefits most from special policies supporting ORE or policies limiting solar PV.



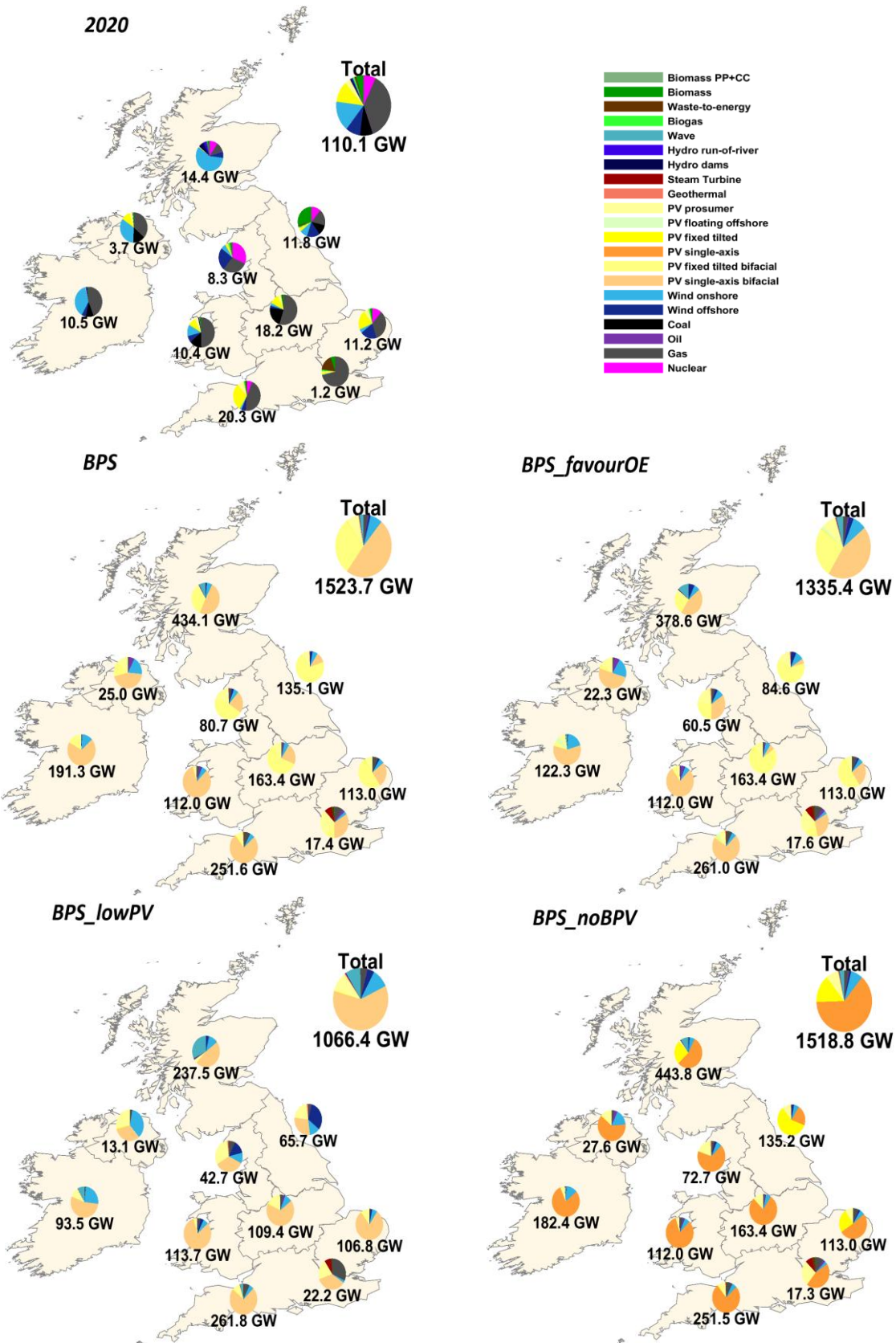

Figure 9 - Regional electricity generation capacities in different scenarios in 2020 and 2050.



This project has received funding from the Europeans Union's Horizon 2020 research & innovation programme under grant agreement number 101036457.

For **Ireland**, as Figure 10 indicates, installed capacity in the BPS\_favourOE rises sharply from 10 GW in 2020 to 123 GW by 2050, reflecting a large-scale RE-based transition. Onshore solar PV expands most dramatically, from 0 GW to 89 GW, accounting for nearly three-quarters of new capacity additions. Onshore wind power grows steadily to 24 GW by 2035 and then stabilises. OSPV and wave power make small contributions after 2040, highlighting emerging diversification. Fossil gas capacity falls from 5 GW to just 1 GW, and coal is completely decommissioned. The role of ORE is limited compared to regions of England or Wales as the available onshore RE potential in **Ireland** is sufficient to satisfy local energy demand and even provide energy for export. In the BPS\_lowPV, wave power capacities increase to 7.4 GW to compensate the reduced onshore RE capacity.

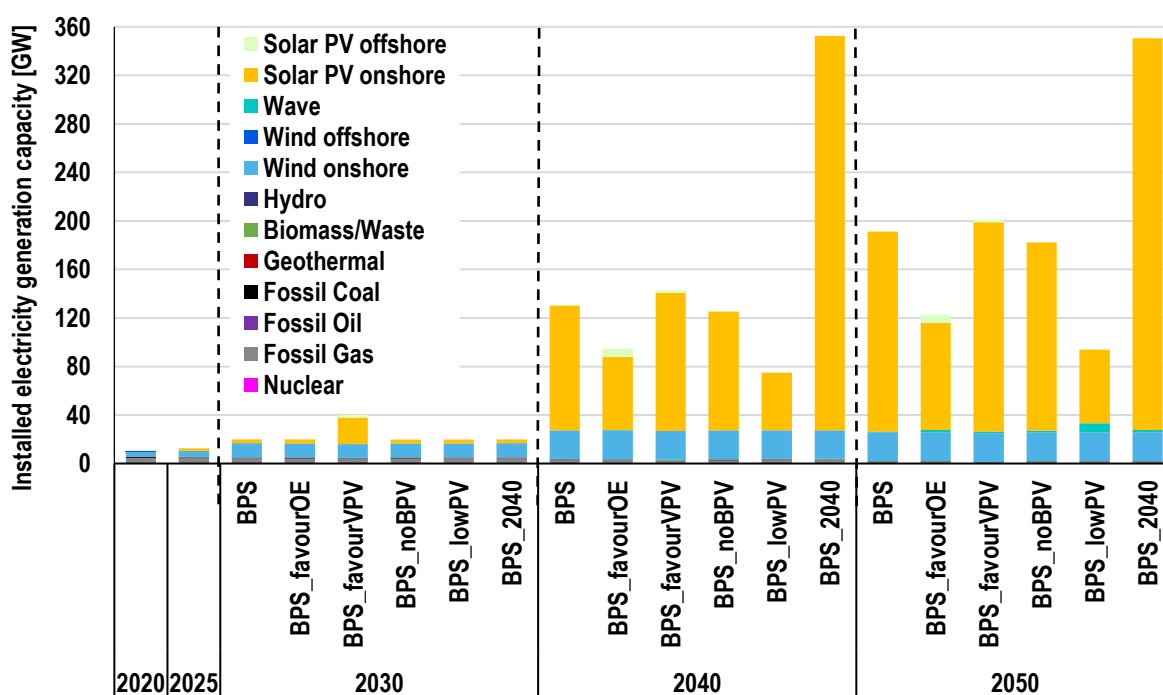

Figure 10 - Installed electricity generation capacities for Ireland across all the scenarios during the ET.

The transition of electricity generation between 2020 and 2050 for the **entire region**, reflects a complete overhaul of the energy mix, characterised by the dominance of RE and the near elimination of fossil fuels. Total electricity generation expands from 337 TWh in 2020 to over 2200-2400 TWh by 2050, depending on the scenario, illustrating the growing role of electrification across all sectors and the success of large-scale RE deployment (see Figure 11).

Solar PV generation in the **entire region** emerges as the leading source of electricity. Onshore solar PV exponentially grows from just 13 TWh in 2020 to



around 1450–1580 TWh by 2050. However, because of its lower full load hours (FLh) relative to other RE technologies, PV does not appear as dominant in the generation mix, as it appeared when considering installed capacity. OSPV contributes to the energy mix, but mostly as a technology accompanying other ORE technologies.

In addition, in the **entire region**, wind power generation maintains a strong and steady trajectory. Onshore wind power increases from 47 TWh to nearly 490 TWh by 2050, providing a reliable backbone for variable RE power. Offshore wind power also grows, albeit modestly, from 41 TWh to around 85 TWh, depending on technological and policy assumptions. Together, solar PV and wind power dominate the mid-century power mix, supplying well over 80% of total generation in most scenarios.

Other RE contribute with smaller but consistent shares in the **entire region**. Hydropower remains stable at around 7 TWh, while biomass and waste generation sustain roughly 35 TWh, indicating their niche role for firm power generation and residual heating applications. Geothermal energy, starting from 43 TWh in 2025, maintains a steady output around 40 TWh thereafter, supporting system flexibility. ORE, particularly wave power, exhibit rapid late-stage growth, reaching up to 540 TWh in the BPS\_lowPV, signalling a potential diversification of RE supply.

Considering offshore wind power, wave power, and OSPV, the share of ORE technologies in the generation mix for 2050 ranges from 12% in the BPS to 23% and 33% in BPS\_favourOE and BPS\_lowPV, respectively for the **entire region**.

In contrast, fossil-fuels and nuclear power virtually disappear in the **entire region**. Gas-fired generation, once dominant at 126 TWh in 2020, collapses to almost zero by 2050, while coal, oil, and nuclear power completely vanish after 2040. The phase-out of these sources reflects stringent defossilisation policies and the displacement of baseload thermal plants by RE and storage.

By 2050 for the **entire region**, the electricity system is almost entirely RE-based, with solar PV as its foundation, complemented by wind power, ORE, and geothermal energy sources. The trajectory indicates both a quantitative expansion and a fundamental transition towards a clean, flexible, and electrified energy future.

The electricity generation of wave power strongly depends on the applied scenario. In the **entire region**, the electricity generation of wave power reaches 195 TWh, 306 TWh, 195 TWh, 247 TWh, 541 TWh, and 173 TWh, in the BPS, BPS\_favourOE, BPS\_favourVPV, BPS\_noBPV, BPS\_lowPV, and the BPS\_2040, respectively, in 2050. Electricity generation of wave power is always part of the energy system, whereas it benefits most from special policies supporting ORE or policies limiting solar PV.



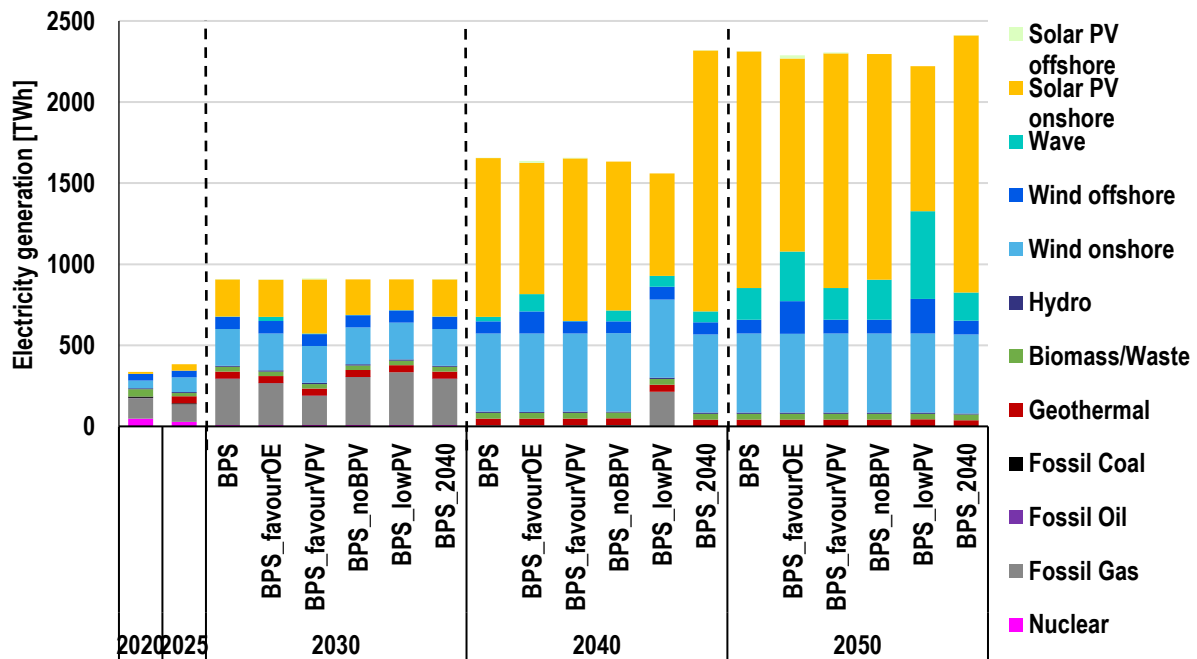

Figure 11 – Electricity generation for all scenarios during the ET for the entire region.

Similar to the electricity generation capacity, a higher share of wind electricity generation is observed in Northern Ireland, Scotland, and the Northeast of England regions (see Figure 12), while a higher share of solar PV generation is concentrated in the southern regions. A more efficient power system is also reflected in the total electricity generation in the BPS\_lowPV, which is the lowest among all scenarios. Solar PV prosumers make a significant contribution in the **UK** and complement utility-scale solar PV generation, while in **Ireland**, Northern Ireland, and Scotland, utility-scale solar PV, wind power, and wave power are appealing. Total electricity generation for the **entire region**, in 2050 is projected to be 2295 TWh in the BPS, 2274 TWh in the BPS\_favourOE, 2281 TWh in the BPS\_noBPV, and 2207 TWh in the BPS\_lowPV. These values for **Ireland** are 303.2 TWh, 233.7 TWh, 290.7 TWh, and 228.1 TWh, respectively, by 2050.



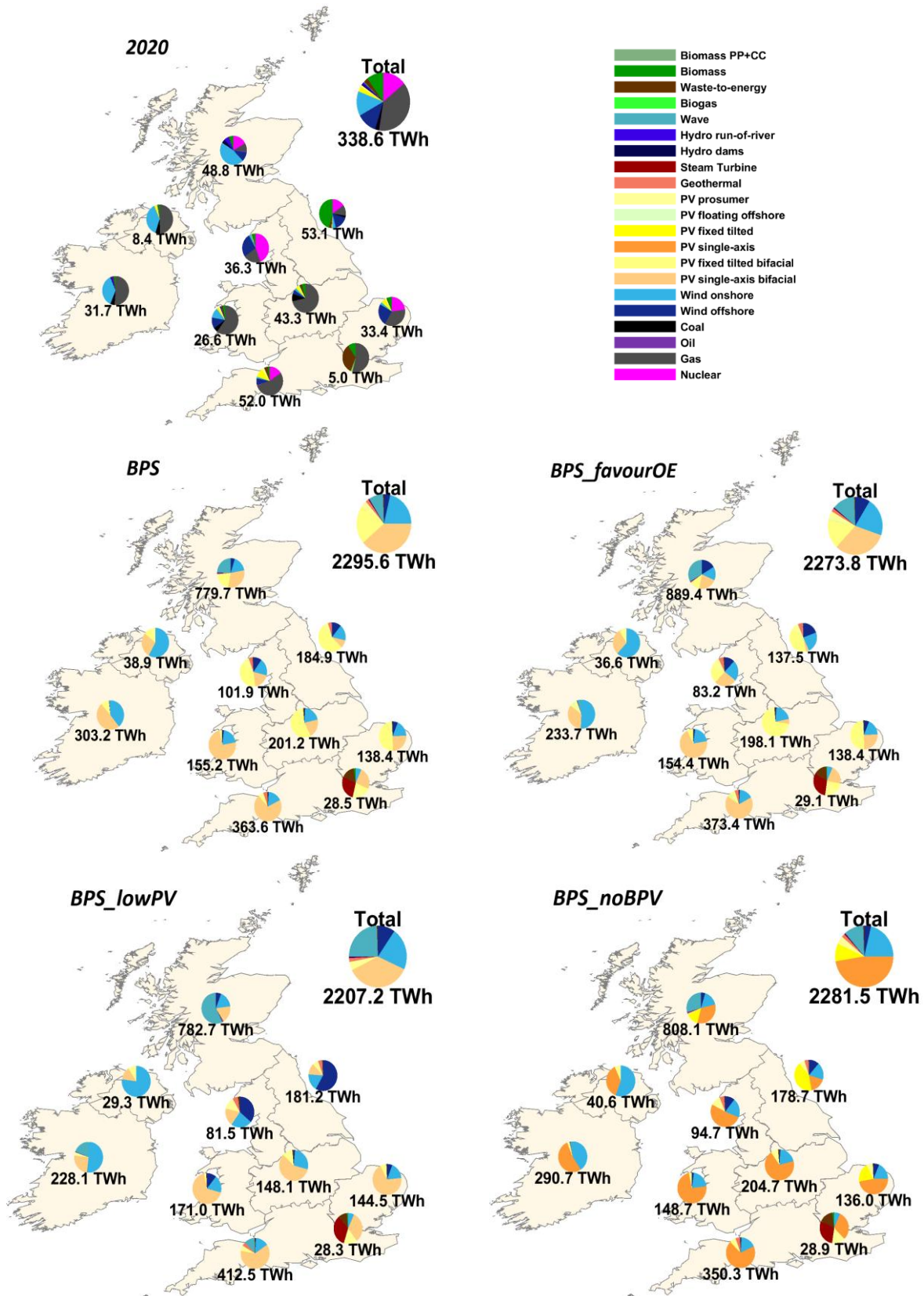

Figure 12 – Electricity generation by technologies during the ET in 2020 and 2050 in different scenarios.



Regarding **Ireland**, electricity generation in the BPS\_favourOE sharply increases from 32 TWh in 2020 to 236 TWh in 2050, driven almost entirely by RE sources (see Figure 13). Onshore wind power dominates, expanding nearly tenfold to 119 TWh by mid-century, while onshore solar PV closely follows, rising from zero to 96 TWh. OSPV and wave power appear after 2040, indicating growing technological diversity. Hydropower and biomass energy remain stable with small but consistent contributions. Fossil fuels, coal and gas, are completely phased out by 2035. Overall, the power mix transitions from fossil fuel-based to a fully RE system, led by wind power and solar PV generation, complemented by wave power.

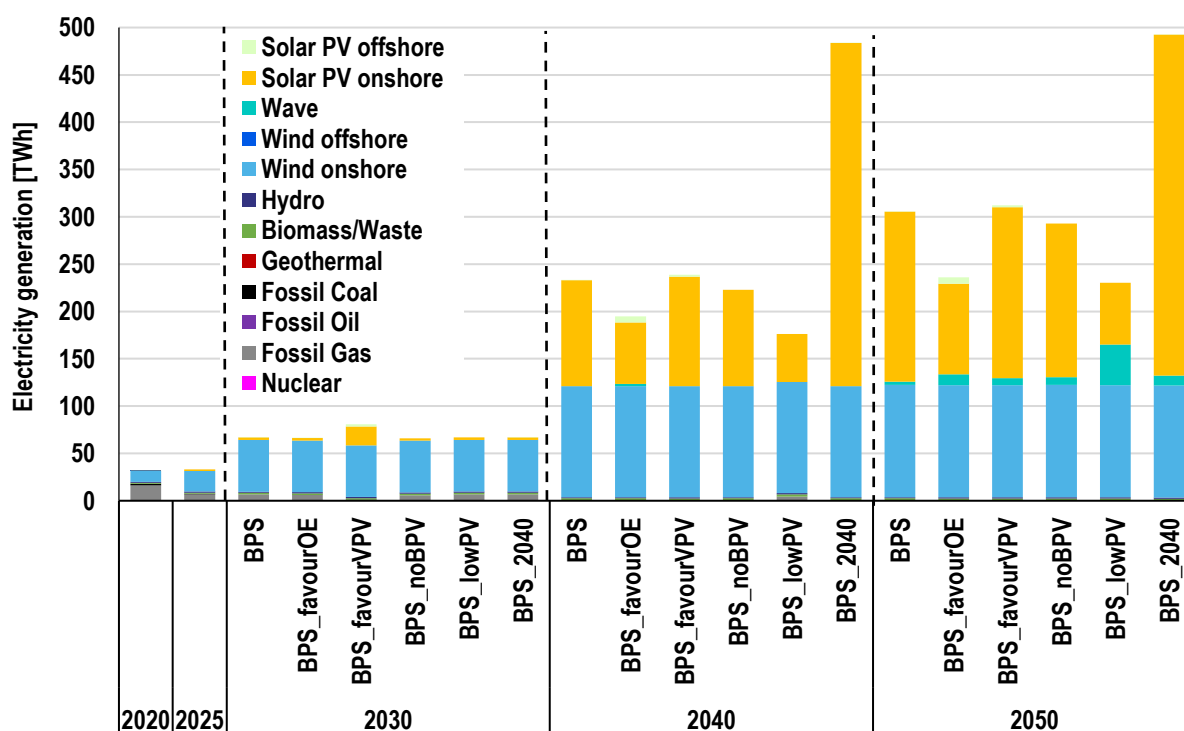

Figure 13 - Electricity generation in Ireland across all the scenarios during the ET.

In the BPS\_favourOE for the **entire region**, compared to the BPS, the installed electricity storage capacity decreases from 1066 GWh<sub>cap</sub> (BPS) to 1058 GWh<sub>cap</sub> (BPS\_favourOE) as Figure 14 indicates. In 2040 in all scenarios except for the BPS\_2040 scenario, the electricity storage capacity reaches 1077 GWh<sub>cap</sub> in the BPS\_2040 and also 1034-1070 GWh<sub>cap</sub> in other scenarios by 2050 (see Figure 14). Also, as Figure 17 shows, the storage throughput is 171 TWh in the BPS\_2040 (the highest among all scenarios), followed by 160 TWh in the BPS\_favourVPV. Consequently, the BPS\_favourVPV and the BPS\_lowPV throughput are about 17% lower, 142 TWh versus 171 TWh in the BPS\_2040 (see Figure 17). The scenarios with the lowest role of short-term storage have the highest share of ORE technologies in the mix and benefit from more stable power generation profiles of the ORE technologies. Figure 15 and Figure 18 present the regional distribution of electricity



storage capacities and output, highlighting the impact of ORE technologies on storage capacity.

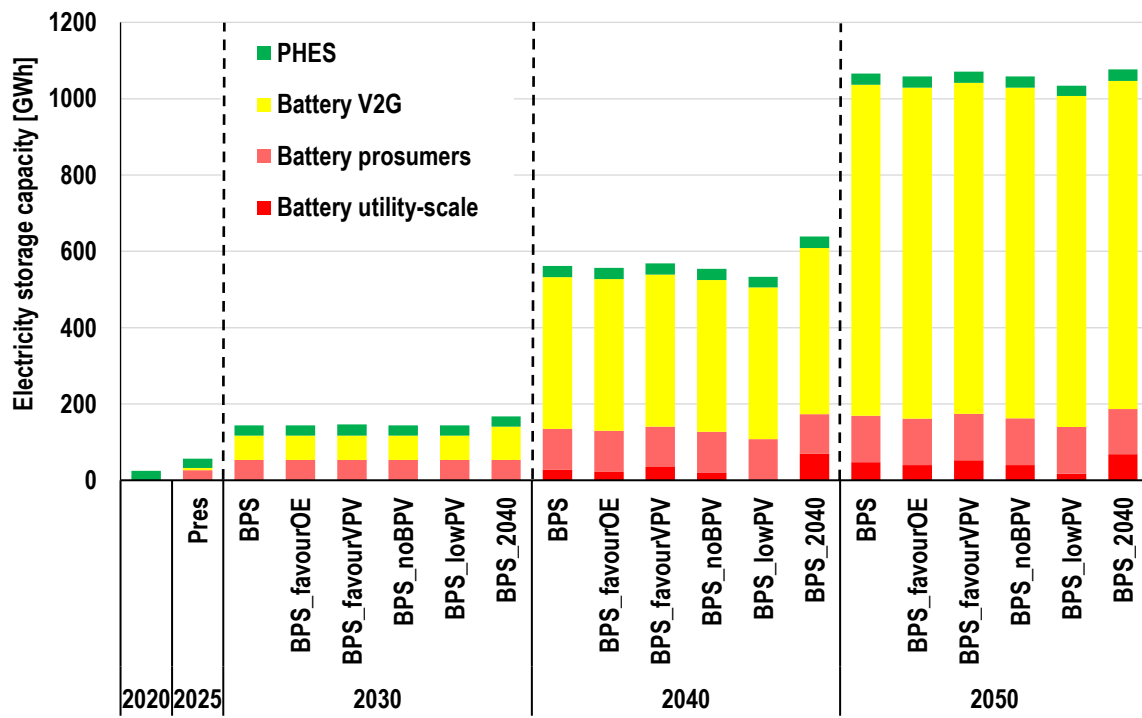

Figure 14 – Electricity storage capacity for all scenarios during the ET in the entire region.



This project has received funding from the European Union's Horizon 2020 research & innovation programme under grant agreement number 101036457.

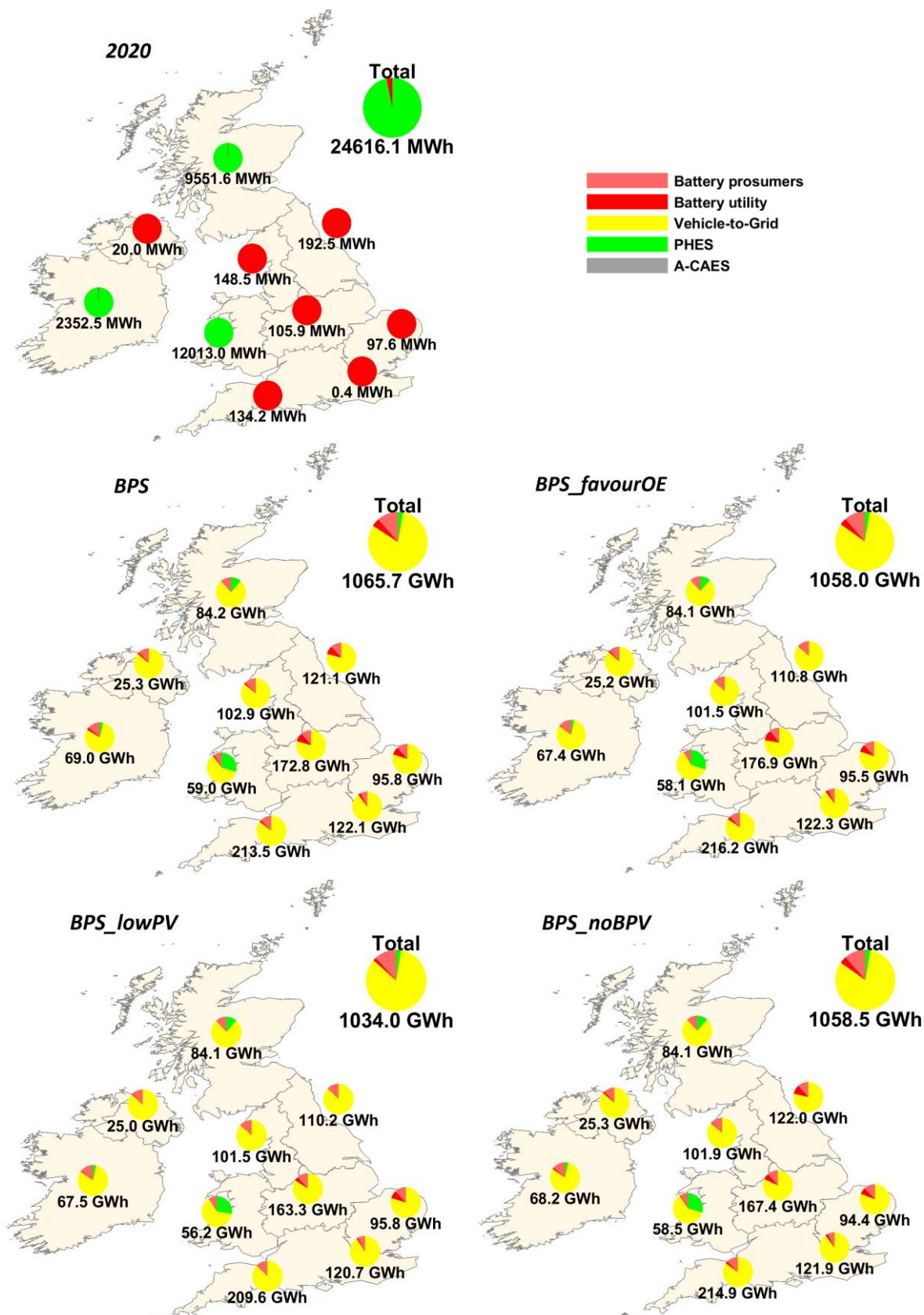

Figure 15 – Regional electricity storage capacities during the ET across different scenarios in 2020 and 2050.



This project has received funding from the European Union's Horizon 2020 research & innovation programme under grant agreement number 101036457.

In **Ireland**, electricity storage capacities in the BPS\_favourOE as Figure 16 shows, significantly expand from 2 GWh in 2020 to 67 GWh by 2050, highlighting its growing role in balancing the energy system. PHES remains constant at 2 GWh, while battery-based technologies drive most of the growth. Prosumer batteries gradually rise to 9 GWh, reflecting household and small-scale adoption. The largest increase comes from V2G, reaching 55 GWh by 2050, over 80% of total storage. This indicates a major shift towards distributed, flexible storage integrated with electric mobility, essential for stabilising variable renewable electricity generation. Figure 15 and Figure 18 present the regional distribution of electricity storage capacities and output, highlighting the impact of ORE technologies on storage capacity. Electricity storage capacities for **Ireland**, in 2050 are projected to be 69 GWh in the BPS, 67.4 GWh in the BPS\_favourOE, 68.2 GWh in the BPS\_noBPV, and 67.5 GWh in the BPS\_lowPV.

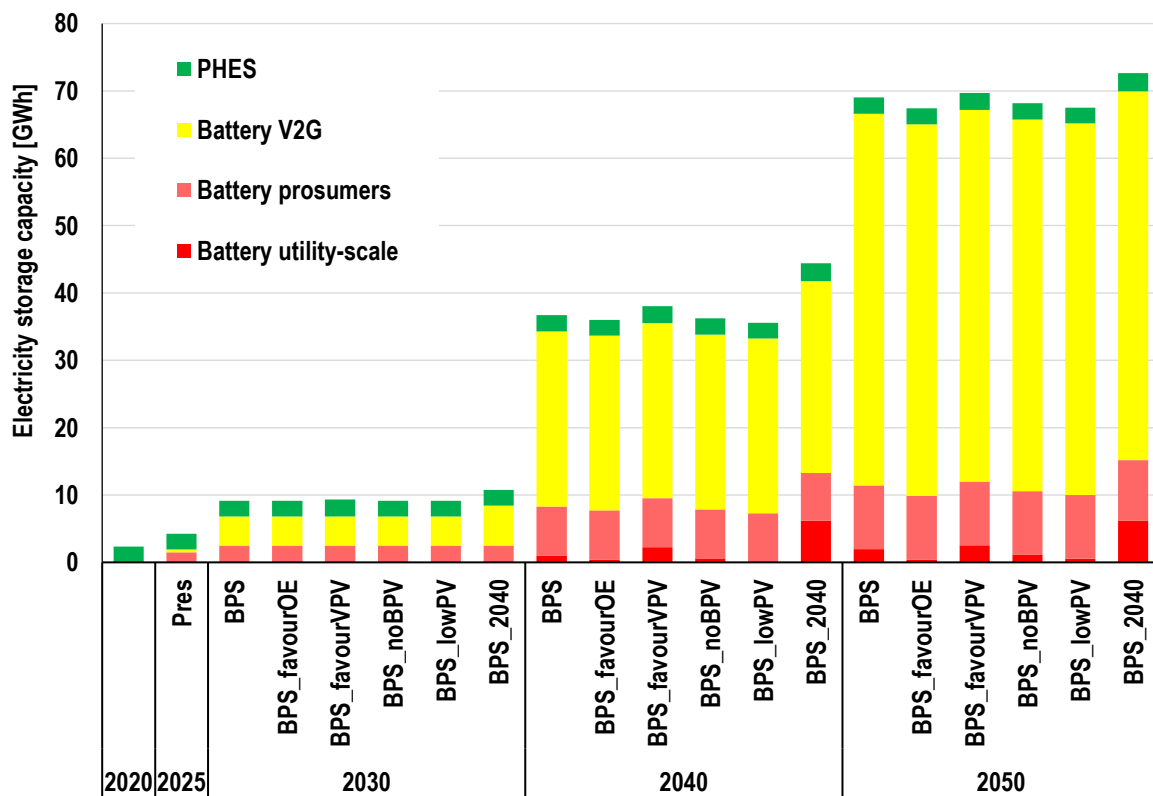

Figure 16 - Ireland electricity storage capacity across all the scenarios during the ET.





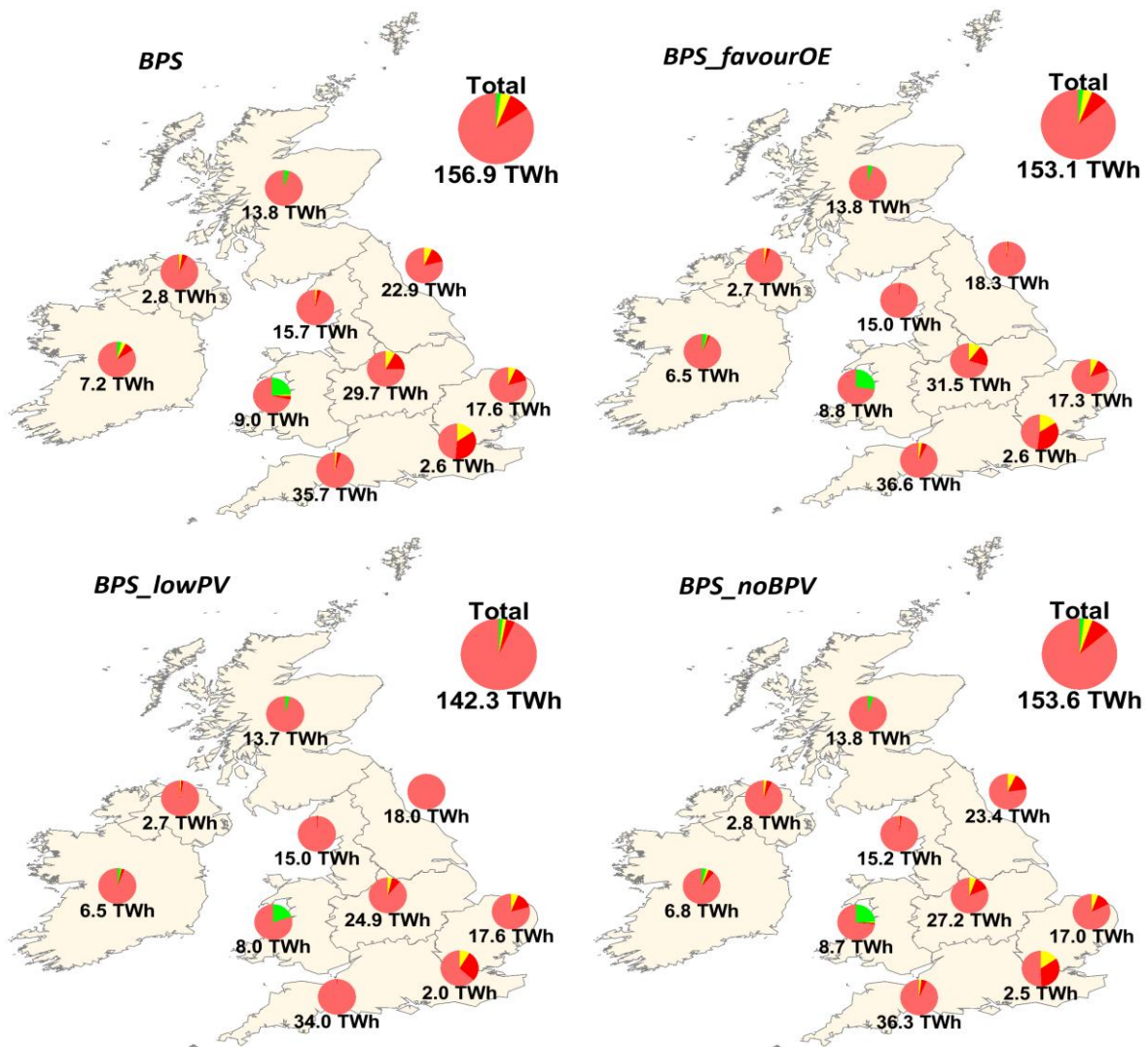

Figure 18 – Regional electricity storage output capacities across different scenarios during the ET in 2020 and 2050.

Regarding the electricity storage throughput in **Ireland** (Figure 19), the total energy storage throughput in the BPS\_favourOE rises from 0.8 TWh in 2020 to 6.5 TWh by 2050, marking a substantial increase in system flexibility. PHES remains nearly constant around 0.3 TWh, providing a stable backbone of large-scale storage. The main growth comes from prosumer batteries, expanding from 2.9 TWh in 2025 to 6.1 TWh by 2050. Conventional and V2G batteries marginally contribute, reaching only 0.1 TWh each. Overall, distributed storage, particularly from prosumers battery, emerges as the key enabler of balancing renewable electricity generation and supporting grid stability towards 2050.



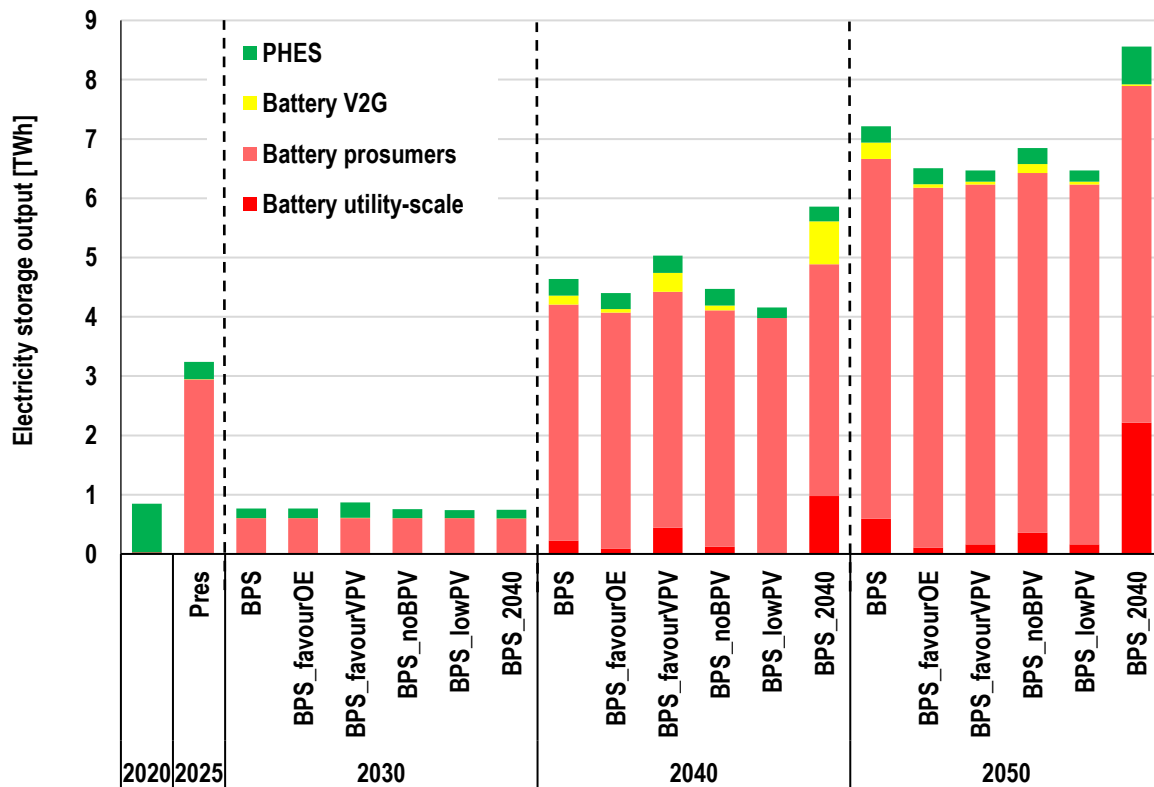

Figure 19 - Ireland electricity storage output across all scenarios during the ET.

### 3.4. Heat supply

Heat is one of the key energy carriers in **Ireland** and the **UK**. Heat demand is mainly composed by space heating, domestic hot water, and industrial thermal processes. In 2020 in the **entire region**, fossil gas was the dominant heat source in both regions, especially in urban areas and the industry sector, while heat pumps and electric heating played a minor role, mostly in rural and residential areas, providing around almost 1.4% of the heat supply despite composing 6.1% of the installed heat generation capacity (see Figure 20). Decreasing technology costs and increasing energy efficiency lead to an increasing share of heat pumps and electric heating. The electrification trend is also evident in the heat sector, both in new installations and in the gradual replacement of gas boilers. Electrification of the heat sector certainly allows for a gradual reduction in dependence and eventually a complete replacement of imported fossil fuels. As Figure 20 shows, by 2050, installed heat pump capacity reaches 73 GW in the accelerated BPS\_2040 scenario and about 80 GW in the remaining scenarios. In 2050, the composition of installed heat capacity in the BPS\_favourOE consists of approximately 20% electric heating (21 GW), 76% heat pumps (80 GW), and 4.7% biomass and waste (5 GW). All scenarios show



similar patterns, though the electrification of heat supply is slightly delayed in the BPS\_lowPV leading to lower electric heating capacities in 2040.

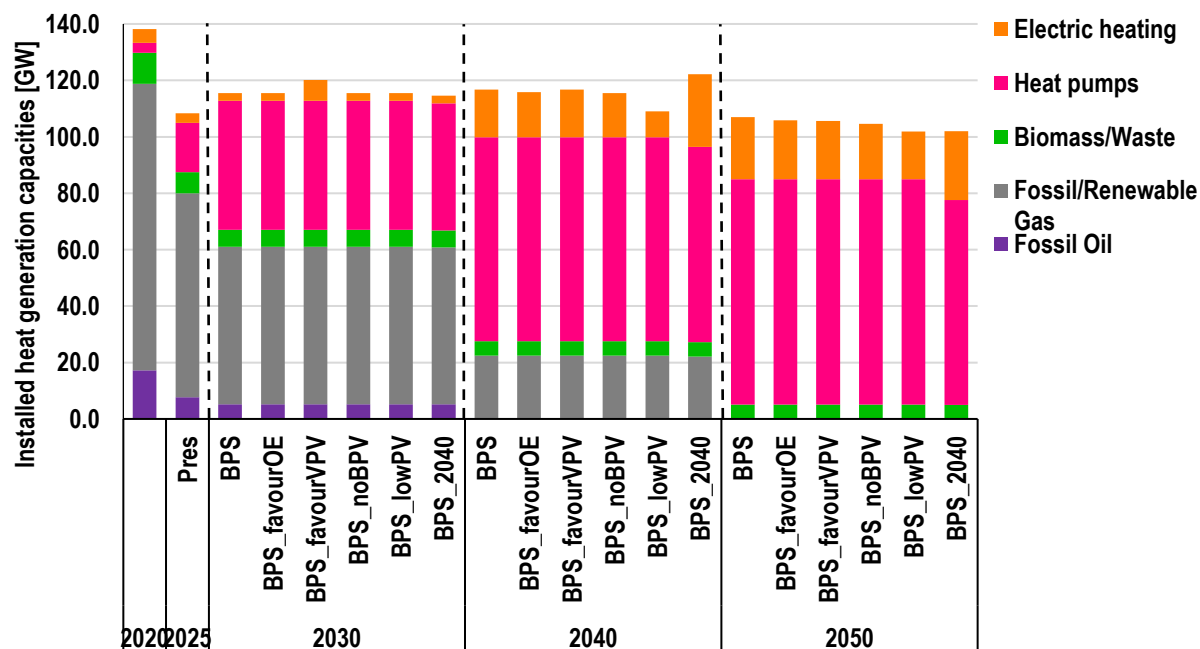

Figure 20 – Installed heat generation capacities in all scenarios during the ET in the entire region.

In 2050, in the **entire region**, in the BPS\_lowPV the installed heat capacity is about 110 GW, which is about 1 GW less than in the BPS with 111 GW. Across all scenarios, the installed capacities range from 109 GW to 111 GW, indicating minimal sensitivity to scenario assumptions for the **entire region** and individual regions (see Figure 21).



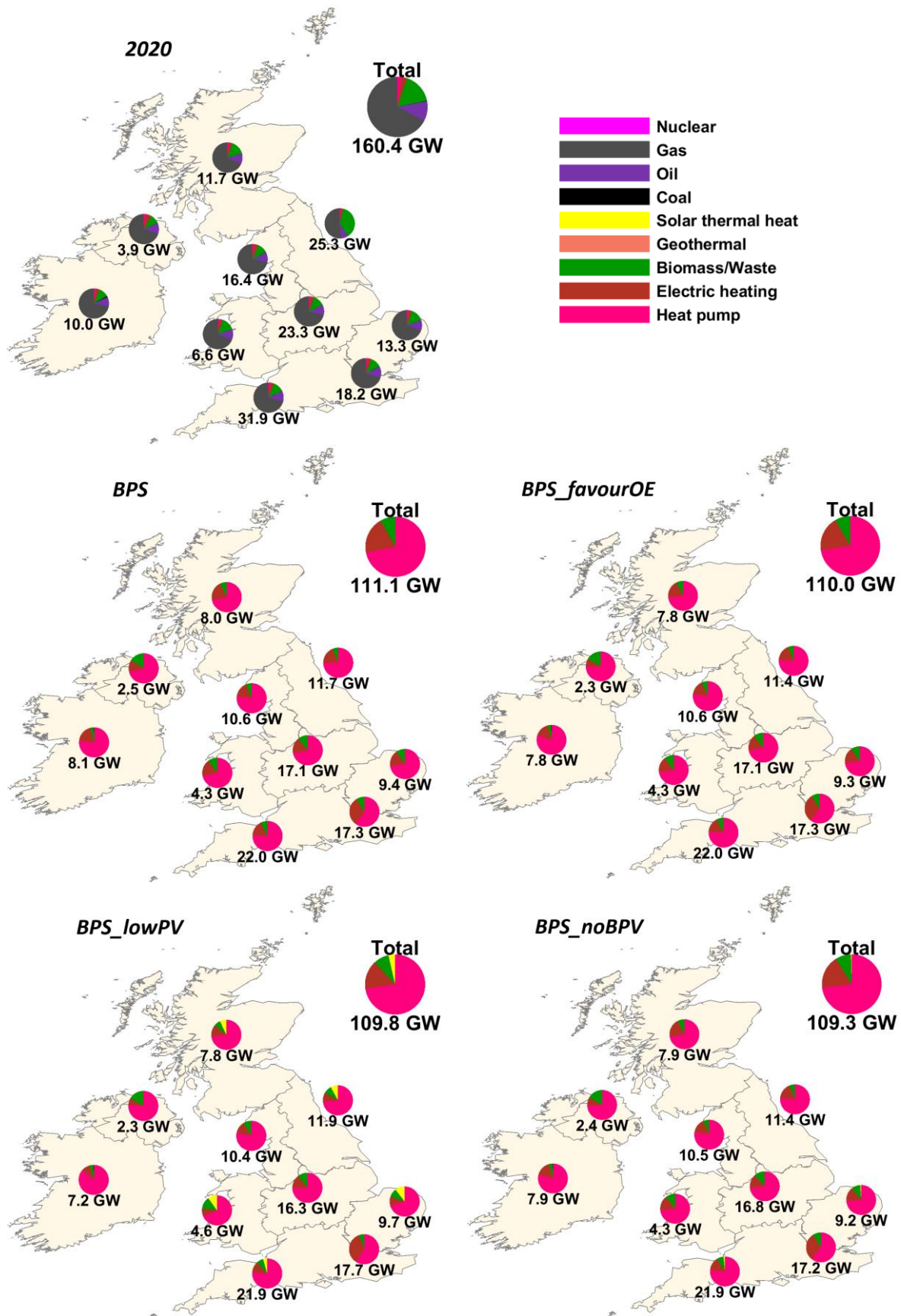

Figure 21 – Regional heat capacities across different scenarios in 2020 and 2050.



This project has received funding from the European Union's Horizon 2020 research & innovation programme under grant agreement number 101036457.

Figure 22 shows the installed heating capacity across all scenarios in **Ireland**, which remains at around 7–8 GW through 2050, but the technology mix shifts dramatically towards electrification. Heat pumps show strong growth, expanding from 1.2 GW in 2025 to 6.2 GW by 2050 in all scenarios (except the BPS\_2040 which is 5.7 GW), becoming the main heating source. Direct electric heating modestly also rises after 2035, supporting peak demand coverage. In contrast, fossil and renewable gas capacity declines from 7 GW in 2020 to zero by 2050, while oil-based systems are fully phased out after 2030. Biomass and waste maintain a small role. Overall, the heat sector transitions from fossil fuels to efficient electric solutions. Scenarios variations mostly impact the power supply structure and have little effect on the heat sector.

In 2050, in **Ireland**, in the BPS\_lowPV the installed heat capacity is about 7.2 GW, which is about 1 GW less than in the BPS with 8.1 GW. Across all scenarios, the installed capacities range from 7.2 GW to 8.1 GW, indicating minimal sensitivity to scenario assumptions also on individual regions level (see Figure 21).

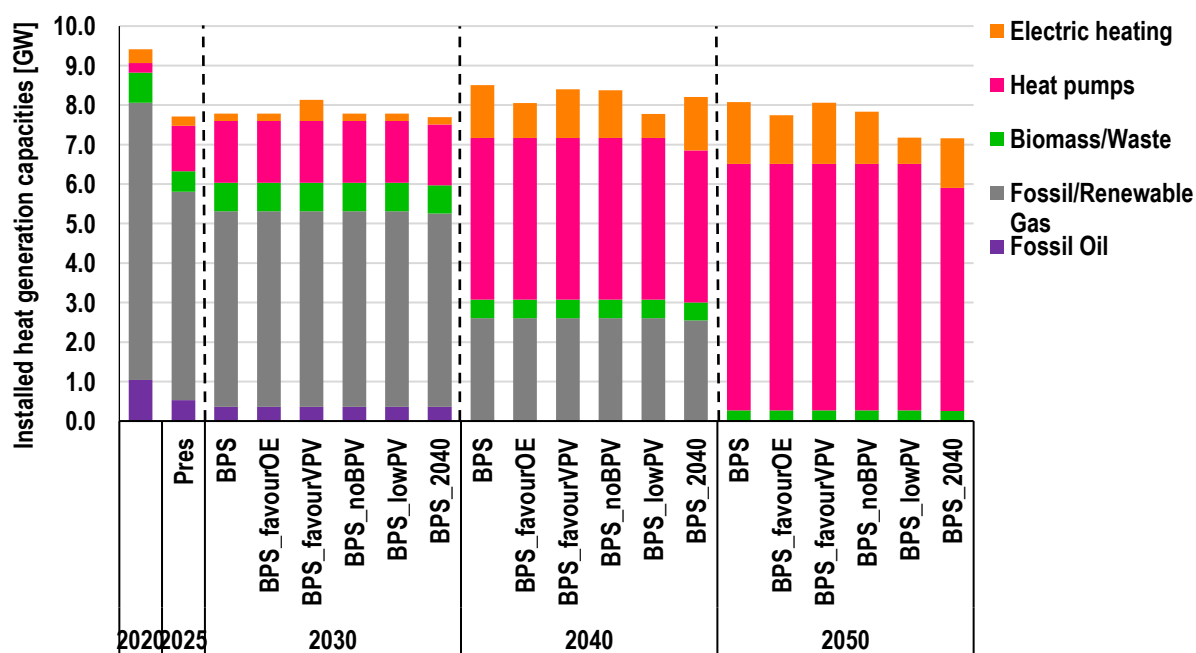

Figure 22 - Ireland heat generation capacities in all scenarios during the ET.

Starting from 2030, for the **entire region**, the share of fossil gas in heat generation declines significantly, by about one-third in energy supply and nearly half in installed capacity across all scenarios. Meanwhile, heat pump capacity remarkably grows from 3.5 GW in 2020 to 46 GW in all scenarios by 2030. The reduction in fossil gas-based heat generation is primarily offset by a rapid expansion of heat pumps, followed by an increase in electric heating, with a modest contribution of biomass



and waste. Despite this structural shift, total heat generation remains relatively stable at around 600 TWh, with a slight rise in the 2040s. In the progressive BPS\_2040 case, total heat generation peaks at 678 TWh in 2040 before sharply dropping to 580 TWh by 2050 (see Figure 23).

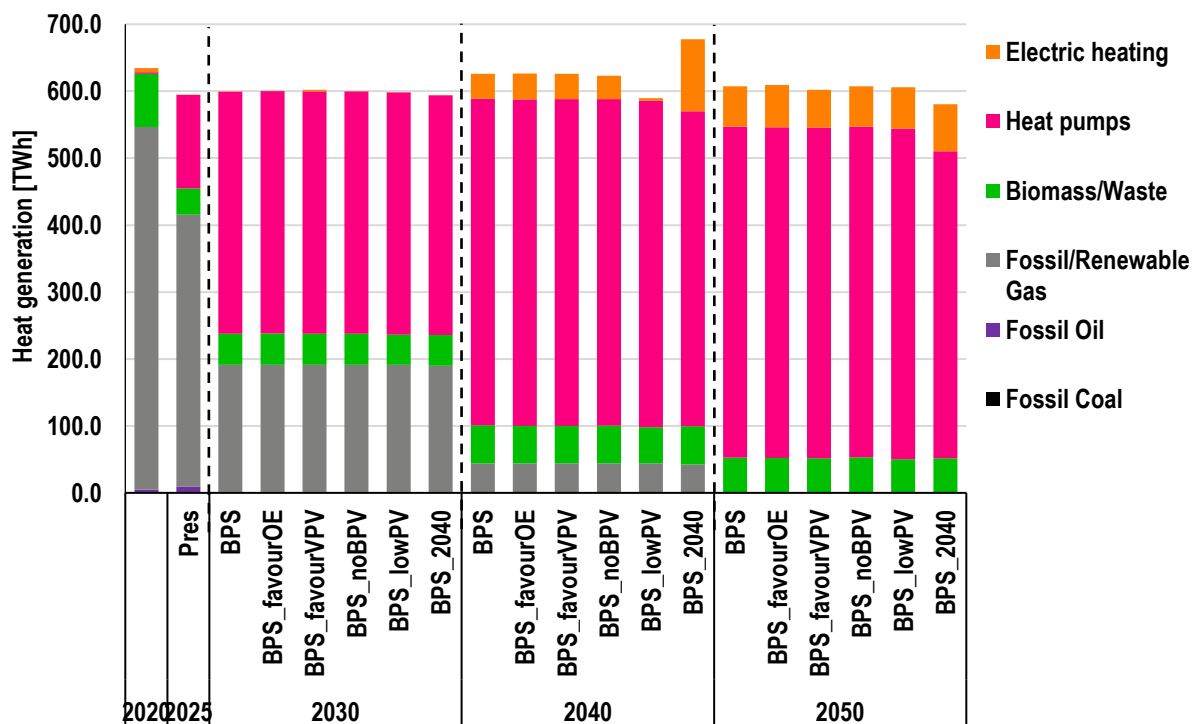

Figure 23 – Heat generation mix in all scenarios during the ET for the entire region.

Figure 24 depicts **Ireland's** heat generation mix in all scenarios during the ET. In the BPS\_favourOE for **Ireland**, total heat generation remains steady around 38–44 TWh through 2050, but the energy mix dramatically shifts towards electrification (see Figure 24). Heat pumps show the strongest growth, from 0.5 TWh in 2020 to 37 TWh in 2050, becoming the dominant heat source. Electric heating also modestly expands to 3 TWh by 2050. Conversely, fossil and renewable gas use plunges from 34 TWh in 2020 to zero, thus, entirely phasing out fossil fuels. Biomass and waste provide a small and stable contribution of about 3 TWh. While other scenarios follow the same trend of the BPS\_favourOE, in both the BPS\_lowPV and BPS\_2040 pathways, the heat supply mix in 2040 is already dominated by heat pumps, accounting for 29 GW in the BPS\_lowPV and 27 GW in BPS\_2040. By 2050, the transition is more pronounced, heat pumps expand to 37 GW in the BPS\_lowPV and 34 GW in BPS\_2040, and electric heating modestly rises to 3 GW and 4 GW, respectively.



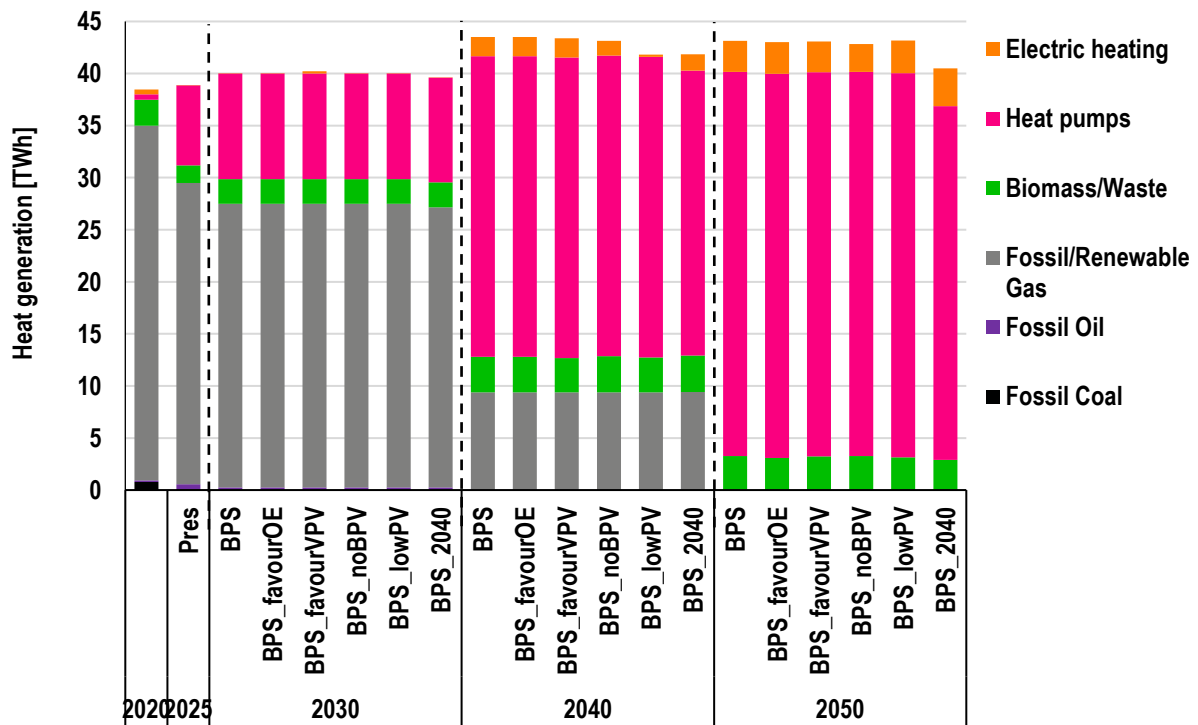

Figure 24 - Ireland heat generation mix in all scenarios during the ET.

Heat storage capacity for the **entire region** shows a rapid and uneven evolution across scenarios from 2020 to 2050 (see Figure 25). In 2020, all technologies start from zero, but by 2030, hydrogen-based storage becomes dominant, reaching between 1160 and 2410 GWh, while methane storage remains marginal, and thermal energy storage (TES) for high-temperature and district heating stays below 1 GWh. In 2040, the total capacity increases notably, yet large variations appear between scenarios: in the BPS and BPS\_noBPV, the total storage reaches over 13,100 GWh, mainly from hydrogen exceeding 12,000 GWh. In contrast, the BPS\_lowPV records a much lower total of 4510 GWh, reflecting a temporary dip before its major expansion in the following decade. In 2040 onward, the progressive BPS\_2040 experiences a dramatic surge, reaching 66,800 GWh in total, driven by substantial increases in both hydrogen (30,130 GWh) and methane (36,570 GWh). The BPS\_favourOE follows with a moderate yet steady rise to 20,580 GWh, while the BPS\_lowPV requires the lowest storage capacities, showing considerably lower storage capacity in both 2040 and 2050. Similarly to electricity storage, the BPS\_favourOE and BPS\_lowPV benefit from a higher share of ORE technologies and more stable electricity generation profiles allowing the system to reduce storage related costs.



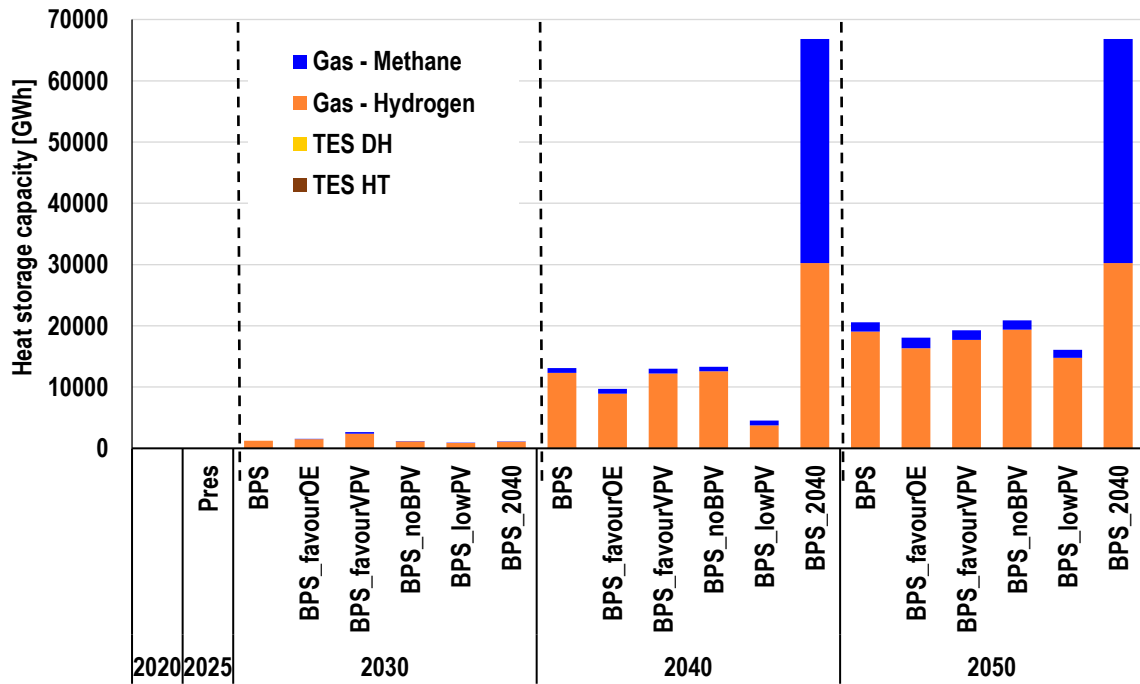
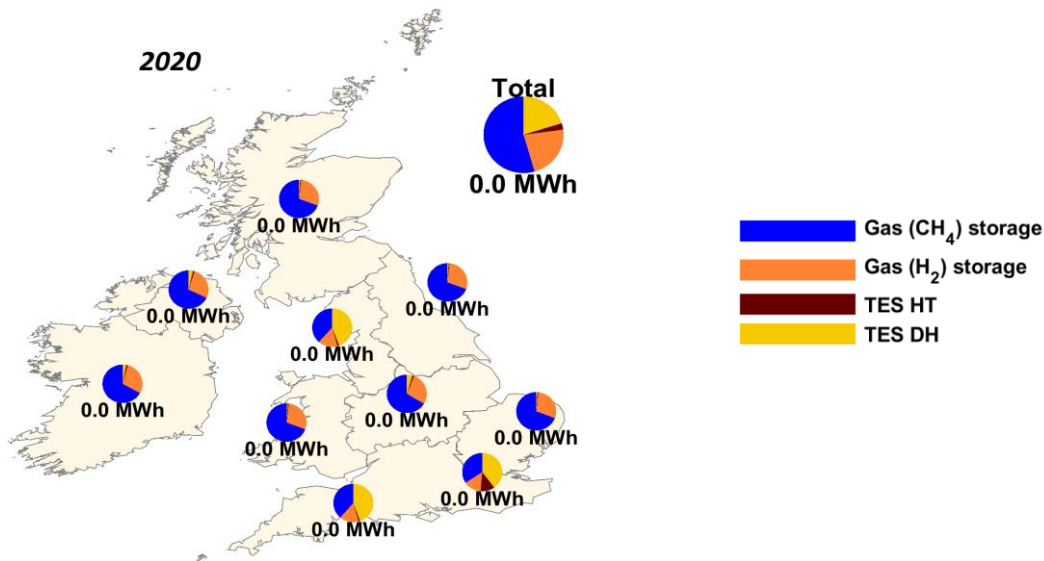

Figure 25 – Heat storage capacity in all scenarios during the ET for the entire region.

At the regional scale (Figure 26) in all scenarios, methane and hydrogen storage shares exhibit roughly the same trend. In the subregional scale, **Ireland**, as other regions, has a dominant hydrogen storage capacity but the methane storage share is considerably high compared to other regions across all scenarios (68% methane storage vs. 32% hydrogen storage).



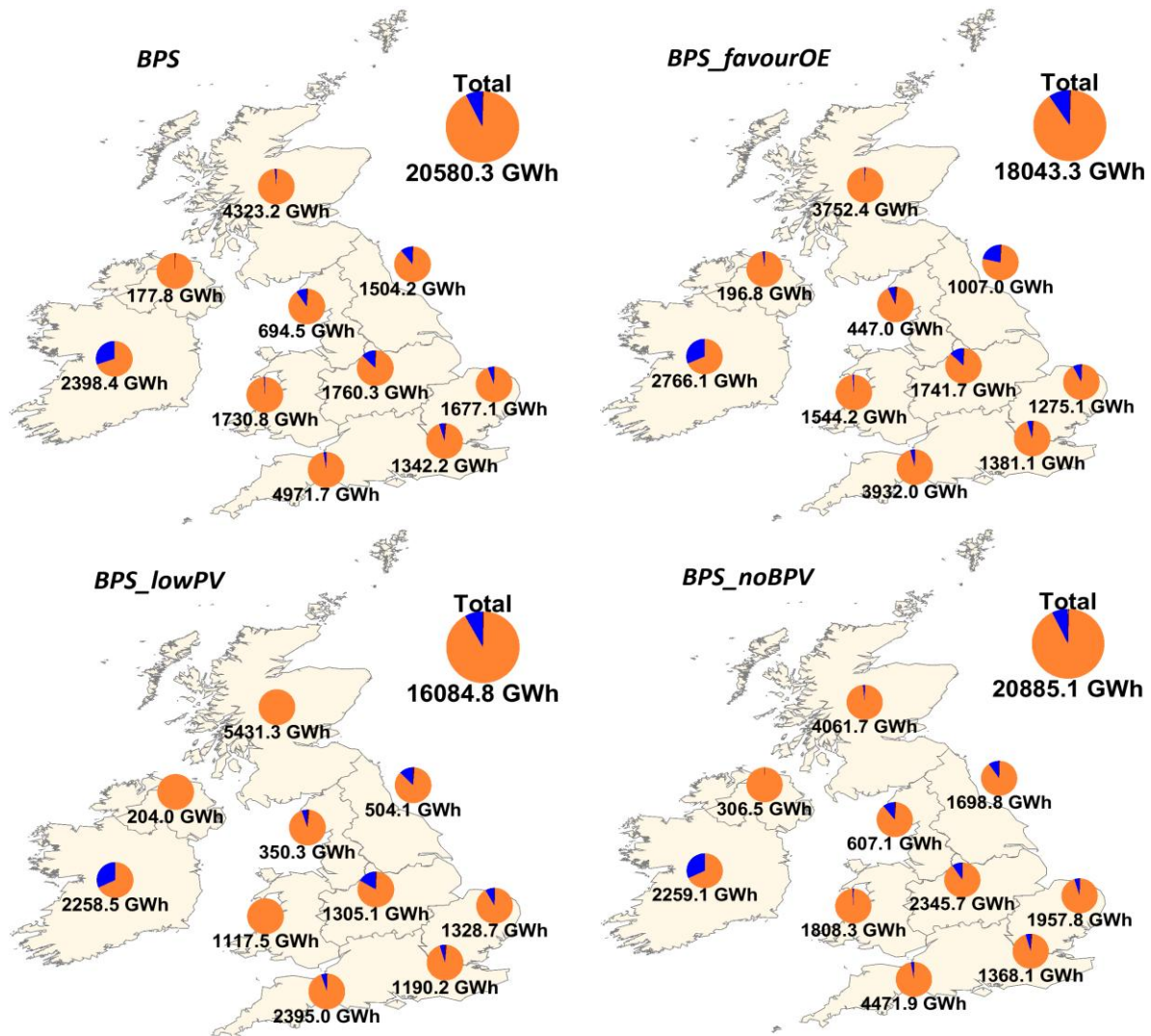

Figure 26 – Regional heat storage across different scenarios in 2020 and 2050.

Energy storage in all scenarios for **Ireland** (Figure 27) rapidly expands. In the BPS\_favourOE, energy storage capacity increases from zero in 2020 to 2766 GWh by 2050, primarily driven by gas-based systems. Hydrogen storage dominates, rising from 227 GWh in 2030 to 1892 GWh in 2050, reflecting large-scale integration of e-hydrogen for long-term energy balancing. Methane storage appears from 2035, reaching 870 GWh by 2045 and remaining stable thereafter. TES plays only a minor role, with high-temperature TES reaching just 4 GWh by 2050. Gas-based storage dominates throughout the ET; hydrogen storage rises from around 200 GWh in 2030 to between 1405 GWh and 1569 GWh by 2040, before substantially expanding to 1531–1892 GWh in 2050, peaking in the BPS\_2040. Methane storage follows a similar pattern with roughly 415–419 GWh installed in 2040, which grows to 723–870 GWh by 2050, with the highest value in the BPS\_2040.



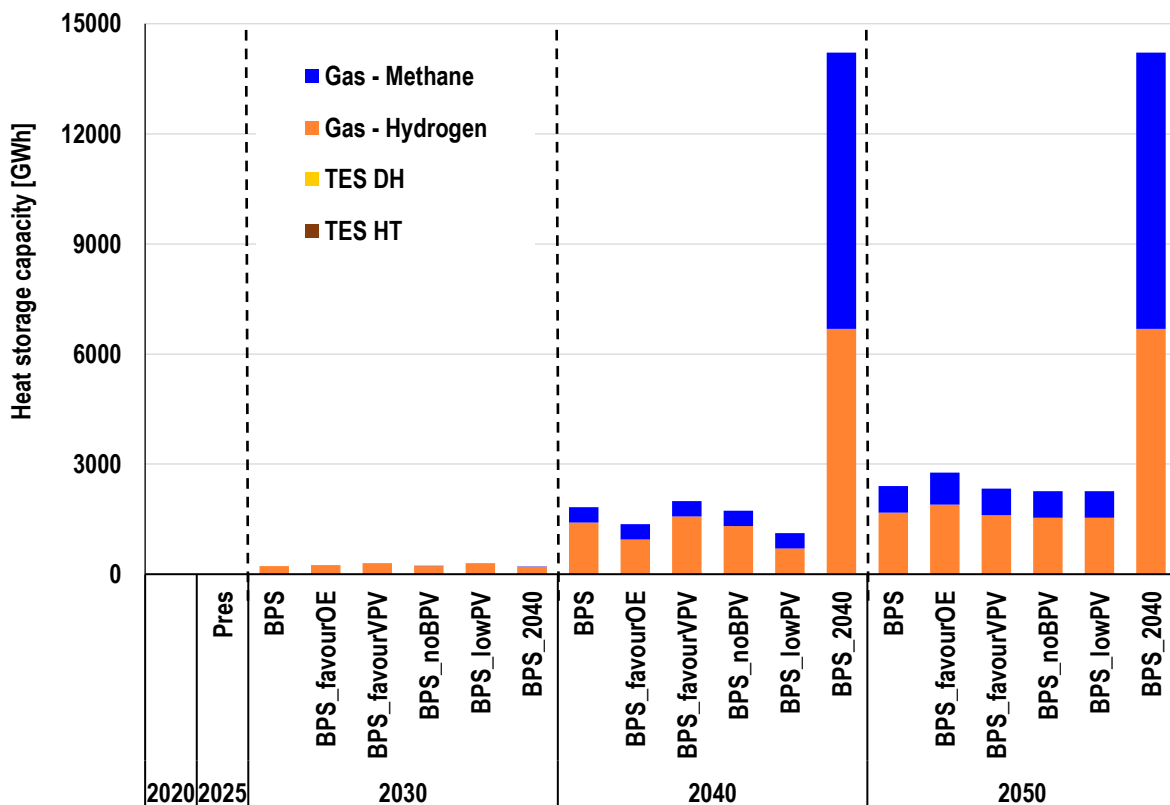

Figure 27 - Ireland heat storage capacity across all scenarios during the ET.

Figure 28 shows the throughput of the heat and gas storage facilities for the **entire region**. Across all scenarios, hydrogen storage shows a significant increase over time, becoming the dominant storage option by 2040 and 2050, while methane storage remains comparatively small. TES contributes less overall, with high-temperature TES (TES HT) maintaining moderate growth, and district heating TES (TES DH) remaining minimal. In the BPS\_favourOE, hydrogen storage throughput expands from 168 TWh in 2040 to 270 TWh in 2050, highlighting its growing role in system balancing. Methane storage throughput also increases slightly, from 1.3 TWh to 2.8 TWh over the same period. Among thermal options, TES HT throughput rises from 10 TWh to 13 TWh, while TES DH remains negligible.

Figure 29, likewise, shows heat storage output in **Ireland** through all scenarios. Across the scenarios, hydrogen remains the dominant form of heat-storage output, but its scale and supporting technologies vary notably. Total heat storage output in the BPS\_favourOE grows from zero in 2020 to 27 TWh by 2050, reflecting major investments in long-term storage solutions. Hydrogen gas storage becomes the dominant technology with its output rising from 4.2 TWh in 2030 to 25 TWh by 2050, highlighting its central role in balancing large-scale renewable electricity generation and providing seasonal flexibility. Methane-based storage appears after



2035 but remains minor, as output peaks at 1.6 TWh in 2045. TES HT output modestly contributes, reaching only 0.5 TWh by 2050. In the BPS, in 2040, heat-storage output is driven mainly by hydrogen storage (27 TWh), with negligible contributions from TES technologies. By 2050, hydrogen storage output expands further to 89 TWh, while TES HT and TES DH outputs remain modest. In the BPS\_favourVPV, hydrogen storage output reaches 29 TWh in 2040 and expands to around 43 TWh by 2050, with only modest contributions from TES HT and TES DH outputs. The BPS\_noBPV shows 25 TWh of hydrogen storage output in 2040, accompanied by roughly 1 TWh output from both methane and TES DH, before rising to 38 TWh in 2050 while TES outputs stay below 1 TWh. In the BPS\_lowPV, hydrogen output is lower, falling from 16 TWh in 2040 to around 19 TWh in 2050, with methane storage output holding at 1 TWh and TES output remaining with a minimal throughput. In contrast, the BPS\_2040 features greater diversification, by 2040 hydrogen storage output reaches 16 TWh, and by 2050 both TES HT and TES DH outputs substantially increase (1.26 TWh and 64.15 TWh), with hydrogen and methane outputs also rising to approximately 32 TWh and 11 TWh, respectively.

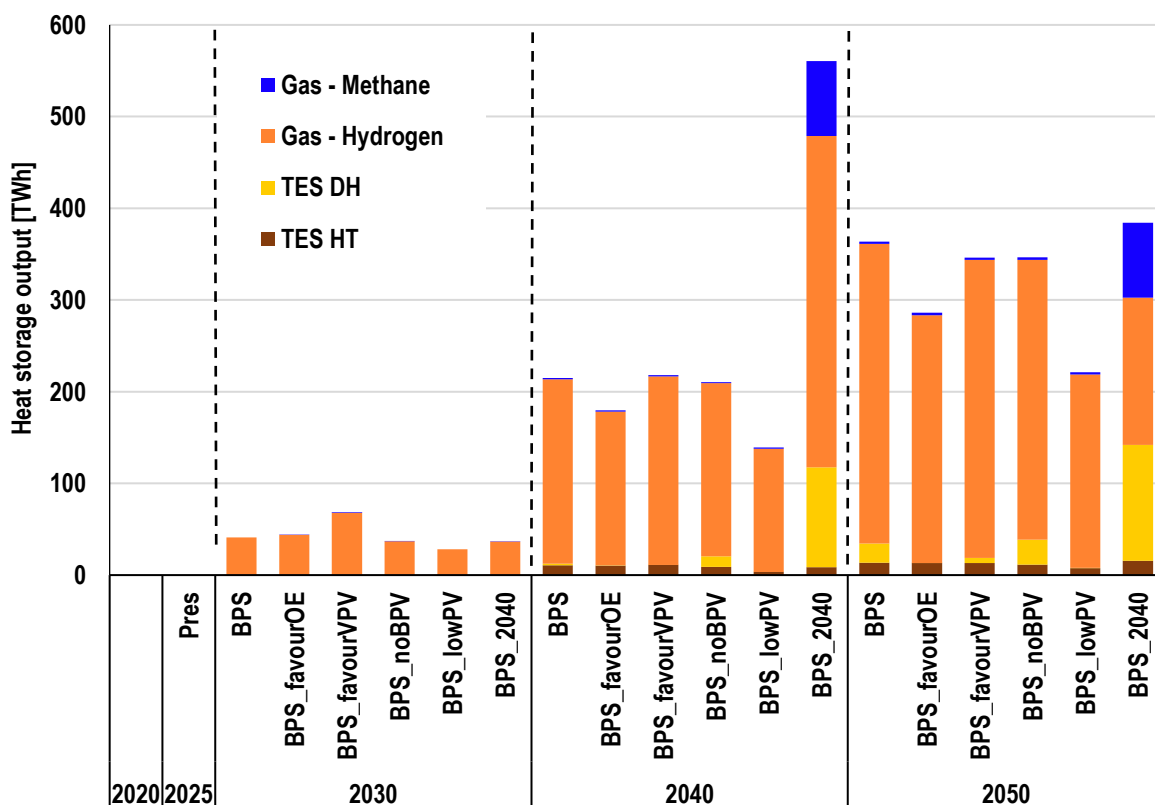

Figure 28 – Heat storage output in all scenarios during the ET in the entire region.



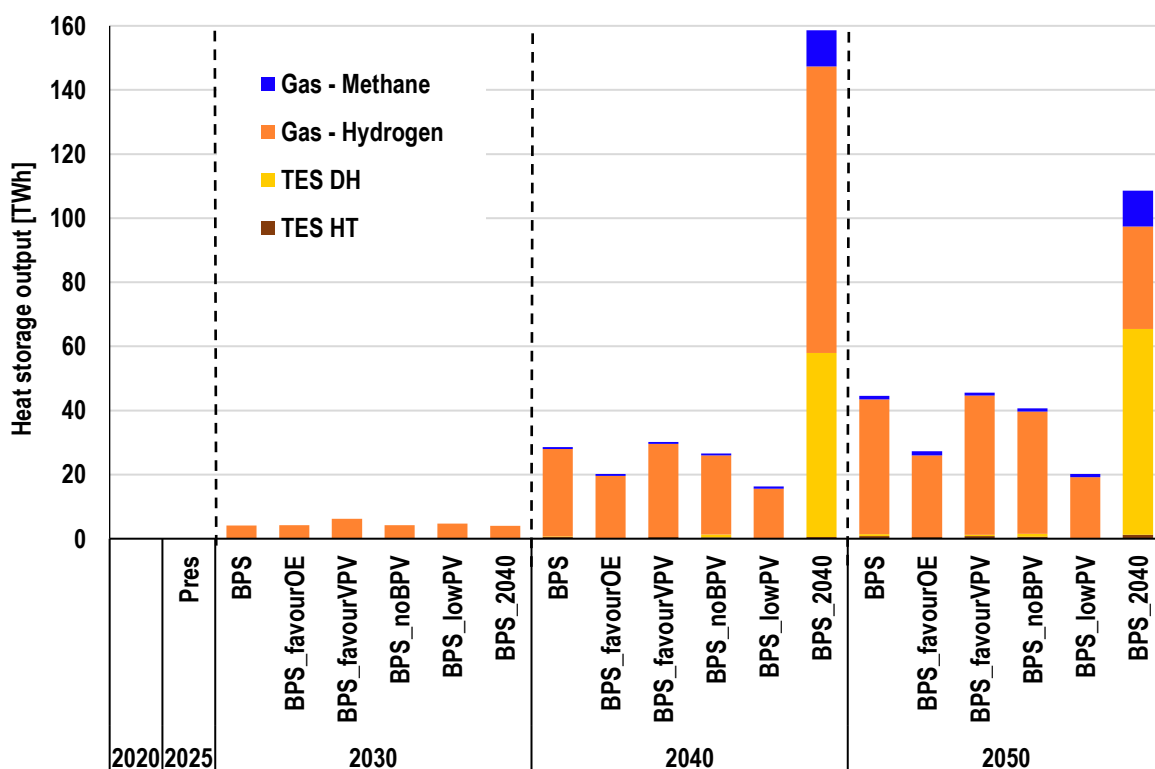

Figure 29 - Ireland heat storage output through all scenarios during the ET.

### 3.5. Transport, industry, and e-fuels

The transport sector plays a significant role in the ET of the region and undergoes significant changes. Electrification and the sharing economy are rapidly changing the FED structure. Figure 30 shows the FED in the different segments of the transport sector in the **entire region**, divided into road passenger and freight transport, rail passenger and freight transport, marine passenger and freight transport, and aviation passenger and freight transport. The road segment has the highest level of electrification. In all scenarios, the FED for road passenger decreases by more than three times (from 355 TWh to 107 TWh) by 2050. This decrease is almost 45% for road freight. Aviation passenger transport is the most energy intensive and continues to consume the largest share of energy in all scenarios. Aviation transport, mainly passenger, has a growing FED in all scenarios from 125 TWh in 2020 to 321 TWh by 2050, as the additional expected demand for transport services cannot be offset by efficiency gains. At the same time, the transport sector's FED transitions from being dominated by fossil fuels to a more diversified energy mix, where electricity represents over 36% and liquid fuels (FT) about 42%, with the remainder coming from various e-fuels and sustainable biofuels. However, the biofuel share remains below 2% because of limited feedstock availability (see Figure 31).



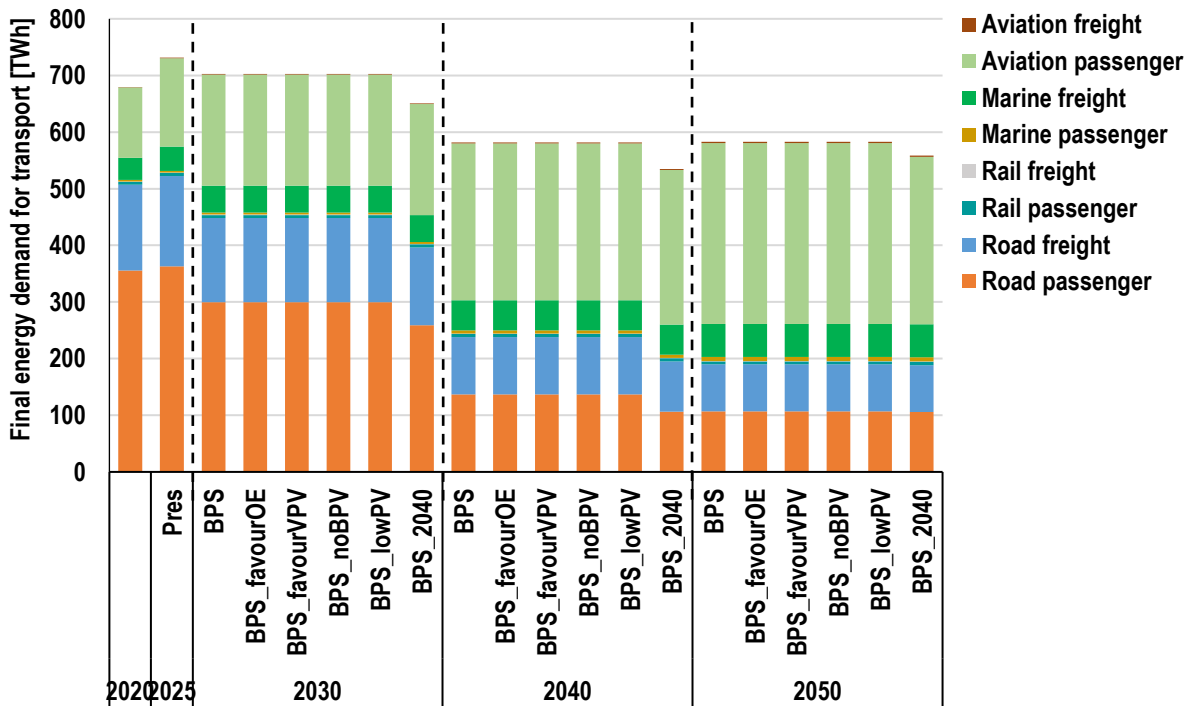

Figure 30 – FED for the transport sector across all scenarios from 2020 to 2050 in the entire region.

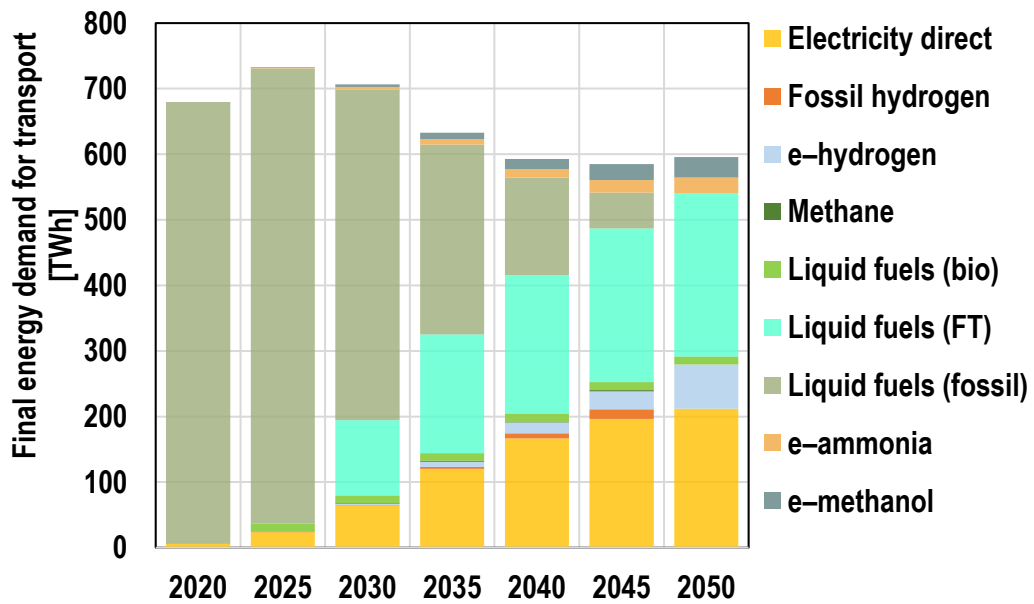

Figure 31 – FED for the transport sector by fuel in the BPS during the ET for the entire region.

Figure 32 indicates the FED in the different segments of the transport sector for **Ireland**. In all scenarios (except the BPS\_2040) the total transport energy demand slightly declines from 58.5 TWh in 2020 to 45.6 TWh by 2050, reflecting efficiency improvements and electrification (see Figure 32). Road transport sees the steepest reduction, passenger demand drops from 30.6 TWh to 6.8 TWh and freight from 13



to 5.3 TWh, indicating a strong shift towards electric or alternative modes. Aviation becomes the dominant energy consumer, growing from 10.7 TWh to 27.5 TWh, largely from passenger flights. Marine transport rises modestly, with both passenger and freight demand increasing. Rail maintains a minor and stable share.

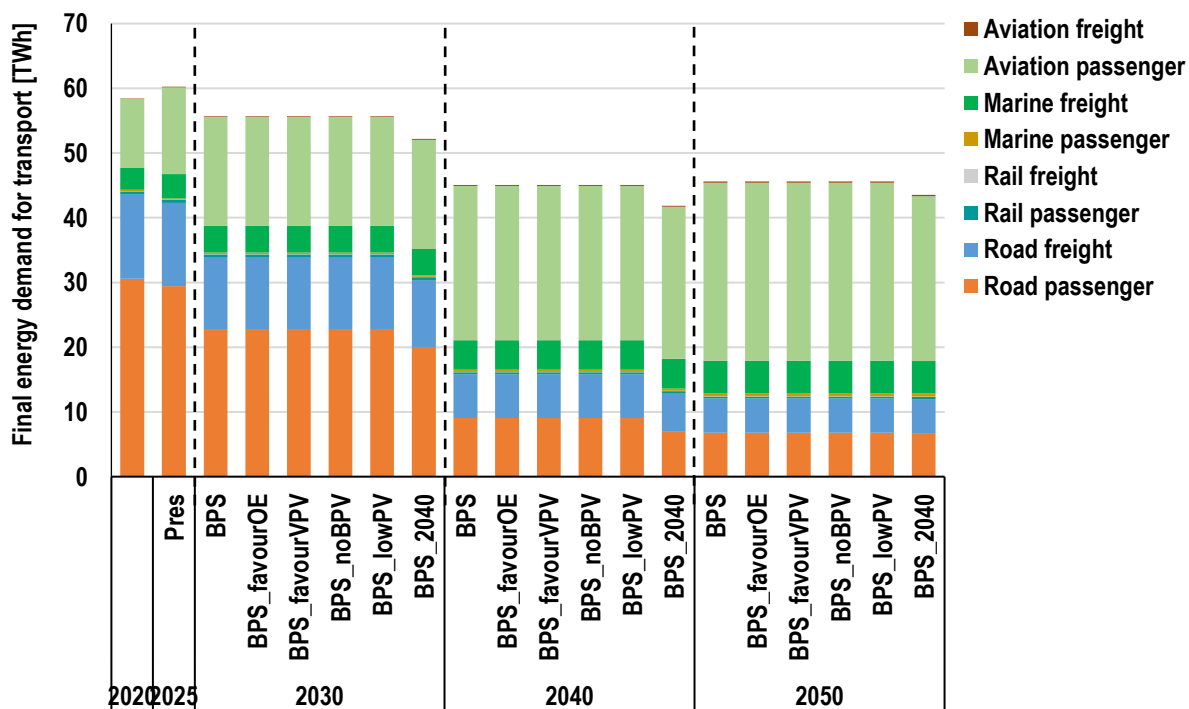

Figure 32 - Ireland FED for transport across all scenarios during the ET.

**Ireland and the UK** have a well-established energy-intensive industrial base, including cement, aluminium, and chemicals production, which are major contributors to CO<sub>2</sub> emissions. This is largely due to their reliance on fossil fuels as an energy source and a raw material. During the ET, however, energy demand in the chemical industry increases, as shown in Figure 33, driven by the rising production of hydrogen-based chemicals. By 2030, the total energy and feedstock demand in this sector is projected to reach 183 TWh, accounting for about 57.6% of total industrial energy demand in the BPS. By 2050, the role of electrolyzers substantially expands, as the chemical industry requires large energy inputs for the production of e-ammonia and e-methanol derived from e-hydrogen as a non-energy feedstock, supporting the shift towards sustainable chemicals production.

The steel industry, on the other hand, experiences the largest reduction in energy use despite slight increase in steel production. Energy demand declines by nearly 41% from 31 TWh in 2020 to 22 TWh in 2050, as processes become increasingly electrified and supported by greater use of secondary steel, while primary steel production switches from coal-based reduction to hydrogen-based direct reduction of iron. In contrast, the aluminium industry sees strong growth, with



energy demand following the production growth and increasing 2.4-fold by 2050 to reach 61 TWh across all scenarios. Meanwhile, energy consumption in the cement and other industries remains relatively stable.

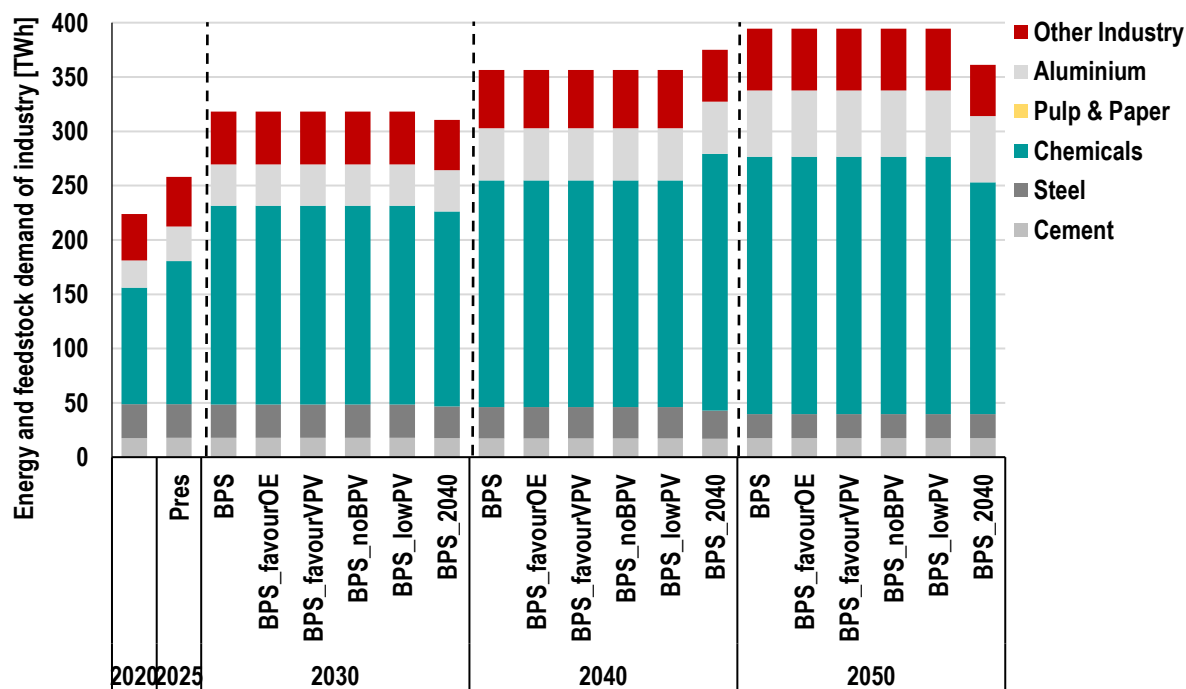

Figure 33 – Energy and feedstock supply for energy-intensive industries across the scenarios from 2020 to 2050 in the entire region.

**Ireland's** industrial energy and feedstock demand shows a mixed trajectory across industries, reflecting both structural characteristics of its industrial base and the impact of defossilisation measures highlighted in Figure 34. The chemical industry emerges as the dominant source of growth, with energy demand rising steeply from 7.4 TWh in 2020 to as high as 24 TWh by 2030 in the BPS and reaching between 22–31 TWh by 2050 depending on the scenario. This increase is primarily driven by expanding production of hydrogen-based chemicals, requiring significant inputs of e-hydrogen as a non-energy feedstock. Aluminium production also steadily grows, doubling from 1.7 TWh in 2020 to 4 TWh by 2030 and reaching 5 TWh by 2050, reflecting both higher output and deeper electrification. In contrast, energy use in cement, steel, and pulp & paper remains largely stable across all scenarios, with cement demand plateauing around 1–1.3 TWh, steel holding near 2 TWh, and pulp & paper remaining negligible. Other industry shows moderate growth (from 2.9 TWh in 2020 to roughly 5 TWh by 2050) indicating incremental electrification but no major structural shift. Overall, **Ireland's** industrial transition is characterised by rapid growth in hydrogen-related industries, stable demand in traditional materials, and moderate electrification in the broader industrial landscape.



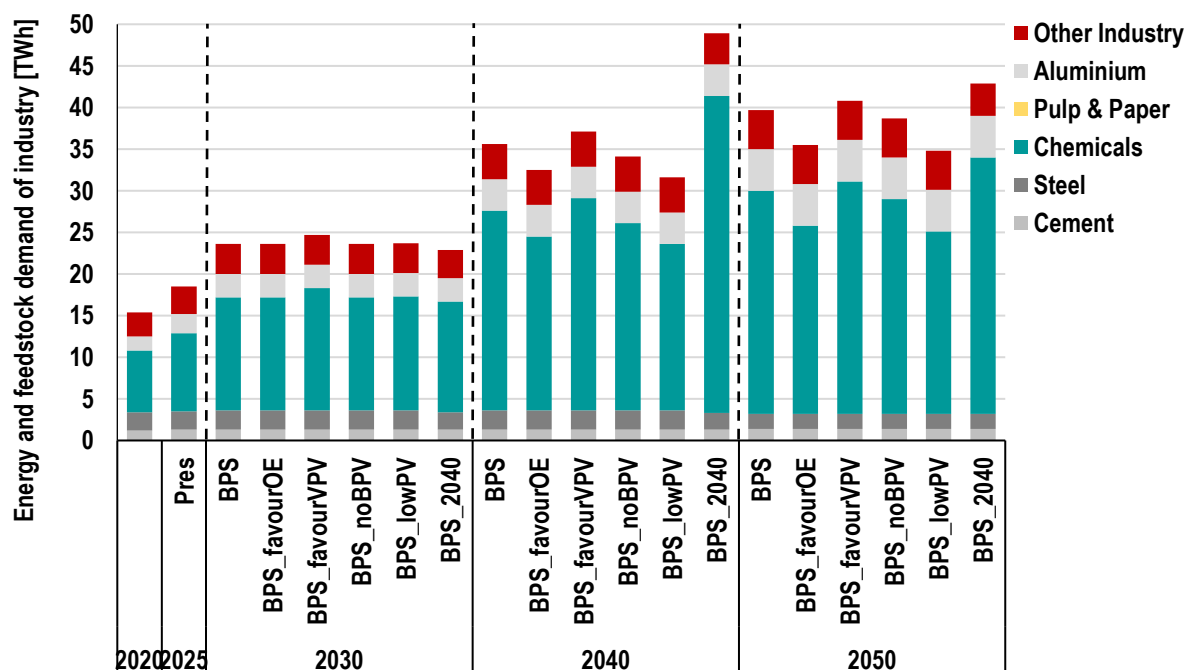

Figure 34 - Energy and feedstock supply for energy-intensive industries across the scenarios from 2020 to 2050 in Ireland.

Industrial-scale production of sustainable e-fuels and e-chemicals is essential to replace fossil fuels in the transport and industry sectors. By mid-century, e-hydrogen emerges as the main industrial feedstock and the basis for synthesising other e-fuels, as well as the primary fuel for aviation and maritime transport. By 2030, most hydrogen is generated through water electrolysis. For the **entire region**, in the BPS, the electrolyser capacity reaches 330 GW<sub>eI</sub> by 2050, exceeding the levels in the BPS\_lowPV (245 GW<sub>eI</sub>) and BPS\_favourOE (280 GW<sub>eI</sub>), as shown in Figure 35. This suggests that the more stable and predictable power generation from offshore wind power, wave power, and OSPV reduces the need for rapid large-scale hydrogen production to ensure grid stability. Consequently, the smoother output from ORE sources helps moderate peaks in e-hydrogen production and lowers the dependence on additional storage capacity, as also noted in the thermal storage discussion.

Installed capacity for fuel and hydrogen production in **Ireland** in the BPS\_favourOE sharply rises from zero in 2020 to 36.2 GW by 2050, signalling a major transition towards green fuels (see Figure 36). Electrolysers dominate this growth, expanding from 0.5 GW in 2025 to roughly 27 GW by 2050, reflecting large-scale hydrogen production from RE. FT and e-methanol technologies follow, reaching 5.8 GW and 2 GW respectively, supporting synthetic e-fuel production. Small capacities emerge for ammonia synthesis (0.7 GW) and methanation (0.1 GW), while fossil fuel-based steam methane reforming (SMR) entirely disappears. Overall, the shift reflects a full transition towards RE-based fuel and hydrogen systems by mid-century. Across scenarios, **Ireland's** fuel and hydrogen production capacities follow the same transition away from fossil-based fuels, but with notable variation in scale



and timing. In the BPS, electrolyser deployment steadily grows to 44 GW by 2050, while FT and methanol synthesis capacities reach 9 GW and 4 GW, respectively, indicating a strong but more moderate e-fuel expansion compared to the BPS\_favourOE. The BPS\_favourVPV accelerates these trends further, pushing electrolyzers to 45 GW and maintaining relatively higher FT and methanol synthesis capacities (9.2 GW and 3.7 GW), reflecting greater availability of variable RE. In the BPS\_noBPV, electrolyser capacity remains high at 41 GW, though slightly constrained; FT and methanol synthesis technologies maintain similar levels to those in other scenarios, suggesting robust e-fuel development. In the BPS\_lowPV, reduced solar PV availability limits electrolyser expansion to 22.1 GW, with proportionally lower capacities across scenarios for e-fuel production. Finally, the BPS\_2040 represents the most aggressive build-out, reaching 93 GW of electrolyser capacity by 2050 and maintaining the highest FT and methanation capacities, illustrating the scale of infrastructure required for an accelerated transition. Across all scenarios, SMR remains phased out, while e-fuel technologies expand to varying degrees depending on RE availability assumptions.

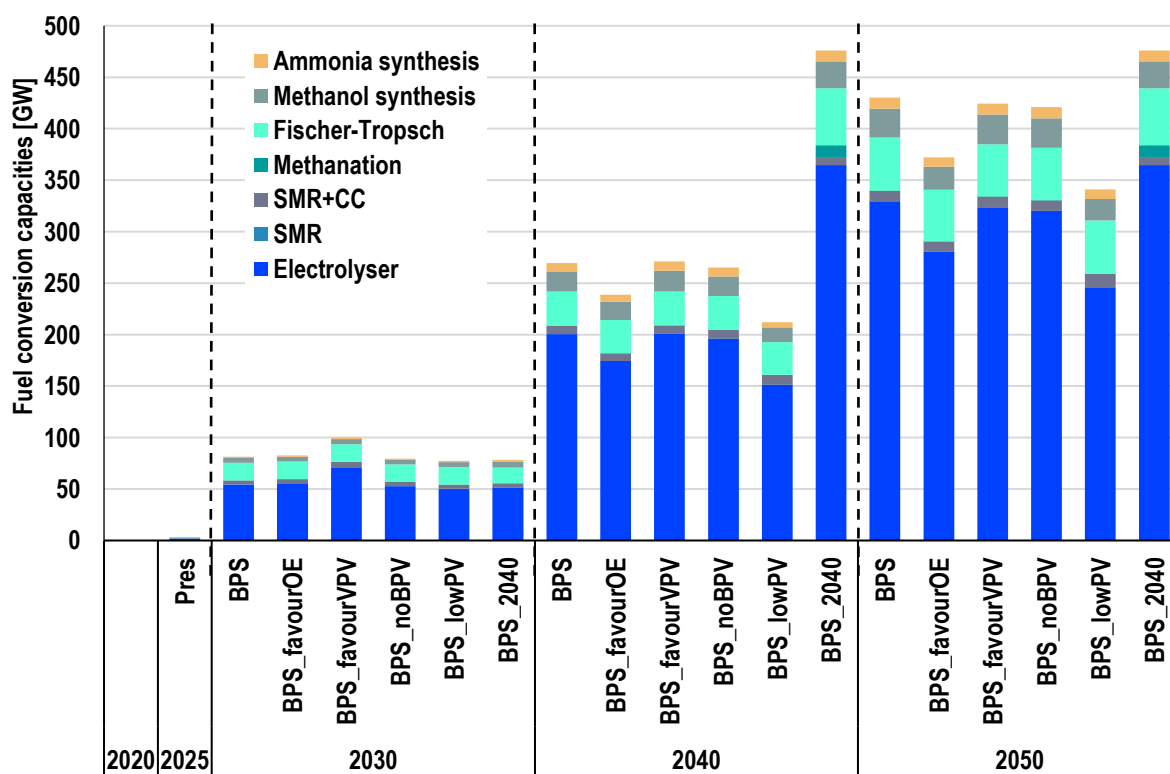

Figure 35 – Fuel conversion capacities across the scenarios from 2020 to 2050 for the entire region.



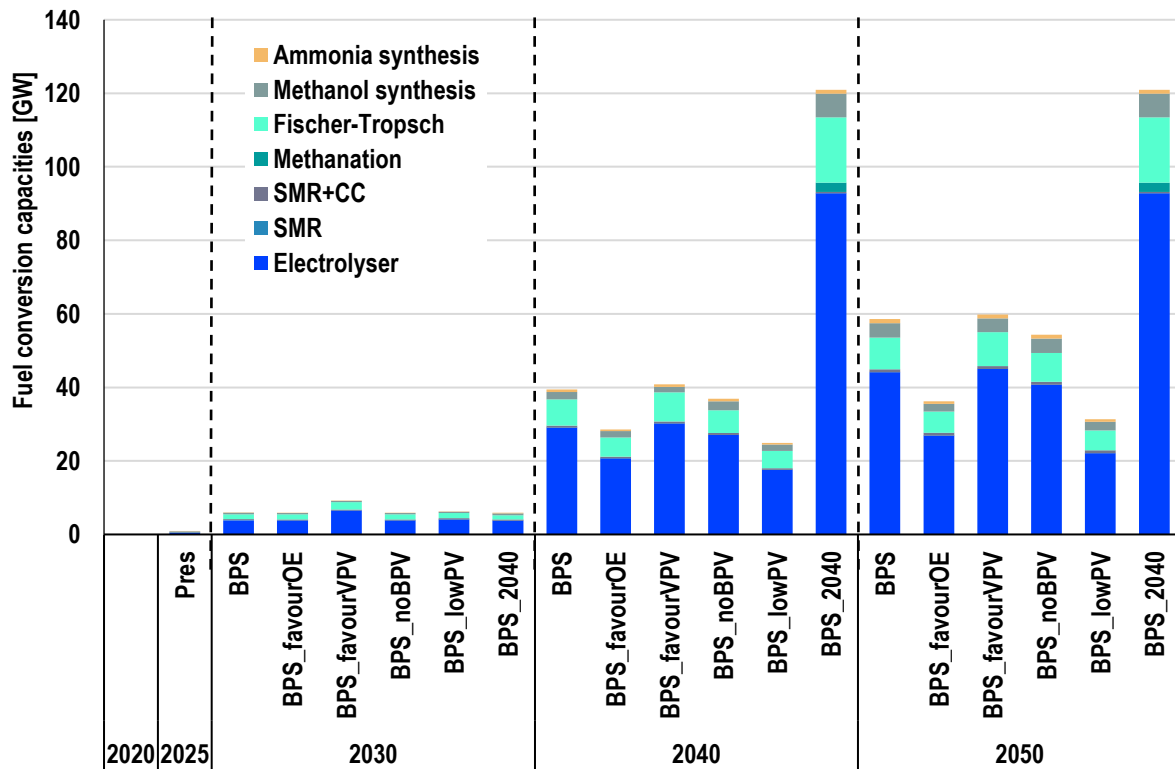

Figure 36 - Ireland fuel conversion capacities through all scenarios during the ET.

### 3.6. Sector coupling and flexibility in the energy system

The coupling of the different sectors of the energy-industry system is key to reduce GHG emissions. This is due to the interaction between different sectors, types of energy use and technological solutions. Flows depicted in the energy flow diagrams in Figure 37 to Figure 40 clearly demonstrate this impact. Figure 37 shows the energy flows in **Ireland and the UK** system in 2020, when the sectors remained largely isolated from each other. Figure 39 indicates the energy flow for **Ireland** in 2020. In turn, Figure 38 and Figure 40 show the energy distribution in the BPS\_favourOE by 2050 for the **entire region** and **Ireland**, respectively, where the integration is more pronounced. In 2020, it is the power sector that is characterised by the greatest diversity of energy sources, while transport, especially road, marine, and aviation, is almost entirely dependent on petroleum products. The heat sector shows moderate diversification but still relies heavily on fossil gas. This indicates that the current energy structure continues to suffer from limited flexibility, high fragmentation, and a significant dependence on fossil fuel imports.



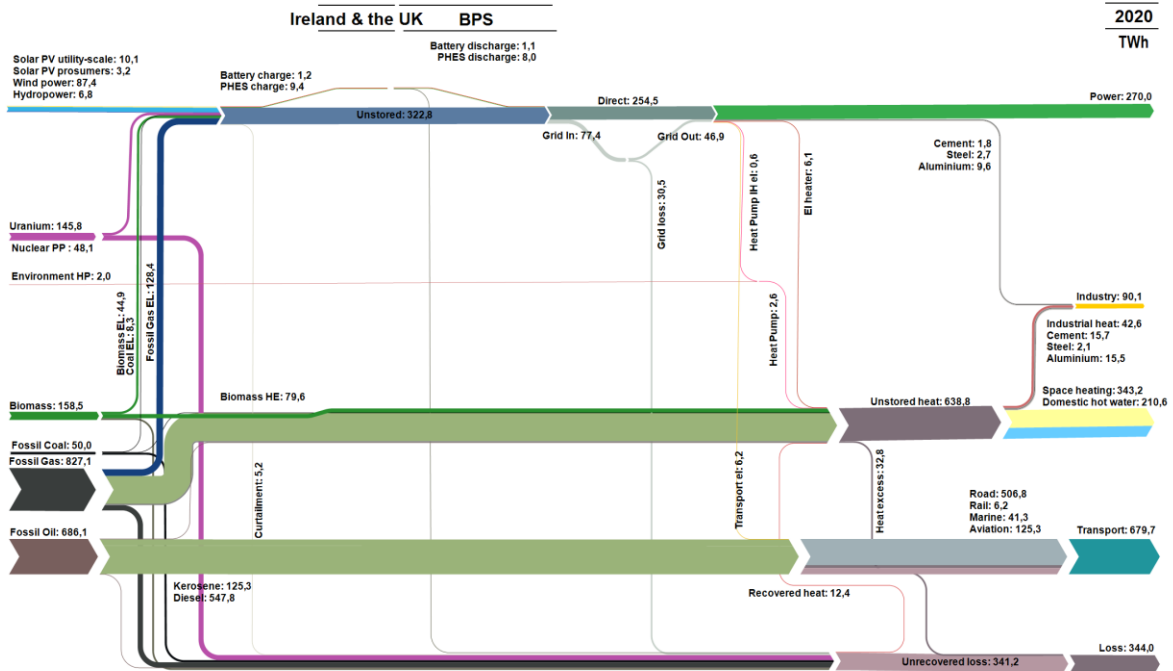

Figure 37 – Energy flows of the entire region energy system in 2020.

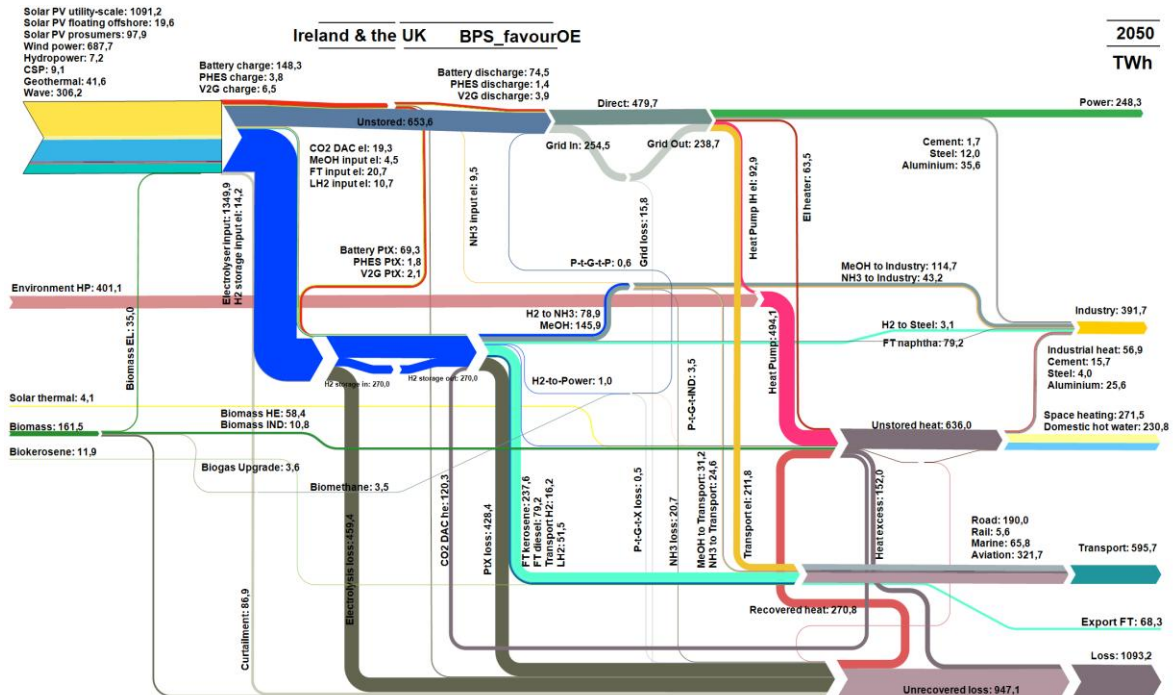

Figure 38 – Energy flows of the entire region energy system for the BPS\_favourOE in 2050.



This project has received funding from the European Union's Horizon 2020 research & innovation programme under grant agreement number 101036457.

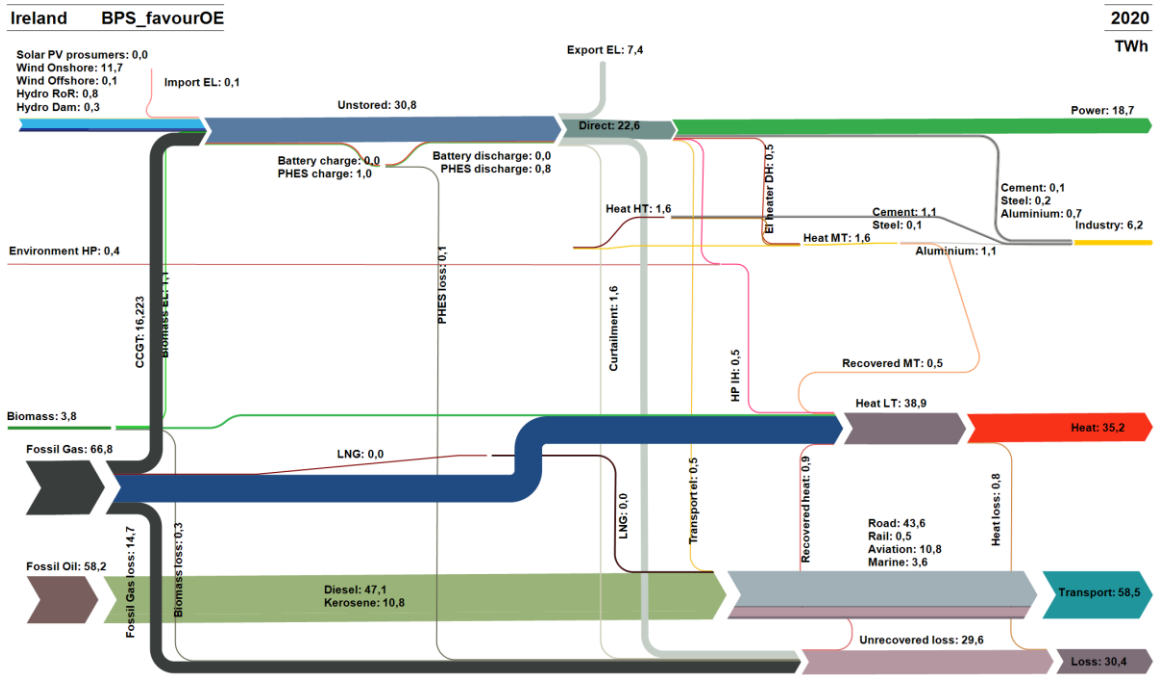

Figure 39 - Energy flows of Ireland's energy system in 2020.

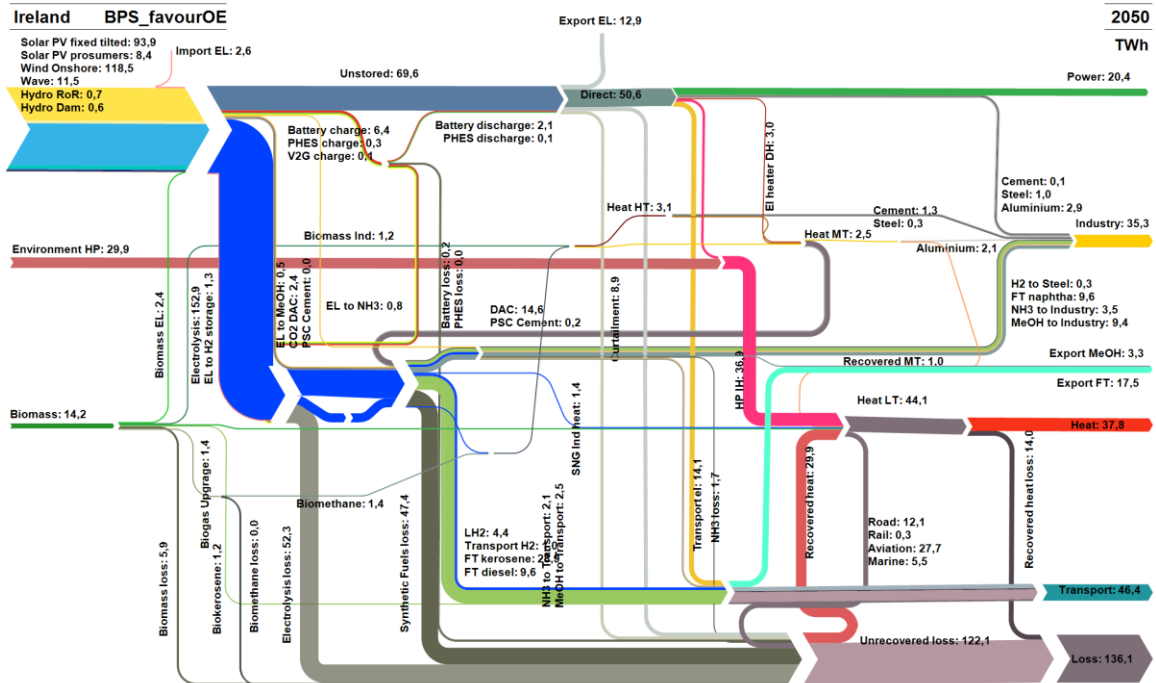

Figure 40 - Energy flows of Ireland's energy system for the BPS\_favourOE in 2050.



This project has received funding from the European Union's Horizon 2020 research & innovation programme under grant agreement number 101036457.

The ET in the **entire region** and **Ireland** across the scenarios results in a more interdependent and integrated energy system by 2050 (see Figure 38 and Figure 40). For the **entire region**, the main characteristic of the energy-industry system is the high share of diversification of the power, heat, transport, and industry sectors. Utility-scale solar PV and wind power dominate the energy system, contributing 1091 TWh (thereof 19.6 TWh of OSPV) and 688 TWh, respectively. Solar PV prosumers add 98 TWh, further emphasising their important role in the energy system. The large electrolyser capacities provide the energy system with significant flexibility, allowing for 1350 TWh of flexible electricity use for electrolysis. Of this, about 14.2 TWh of hydrogen (equivalent to 1% of total hydrogen production) is reconverted into electricity, primarily serving seasonal balancing needs. Regarding **Ireland**, as Figure 40 demonstrates, the energy flow in 2050. As in the **entire region**, the energy-industry system is characterised by a high degree of diversification across the power, heat, transport, and industry sectors. The system is largely dominated by wind power and solar PV, delivering 118 TWh of wind power and 80.2 TWh of solar PV generation (including 6.7 TWh from OSPV). In addition, solar PV prosumers contribute a further 8.4 TWh, underlining the continued importance of distributed solar PV within the overall system. Substantial electrolyser capacities add considerable flexibility, enabling 152.8 TWh of electricity to be used for electrolysis. Of the hydrogen produced, around 1.3 TWh (equivalent to 0.8% of total hydrogen output) is reconverted to electricity, predominantly for seasonal balancing purposes.

Due to their high flexibility, electrolyzers can efficiently respond to variations in electricity generation from variable sources, such as solar PV, wind power, wave power, and run-of-river hydropower. When combined with vehicle-to-grid (V2G) technology, the reliance on energy storage is greatly reduced. Direct electrification is crucial for enhancing the overall efficiency of the power system. Nevertheless, by 2050, the primary contributors to energy losses are e-fuel synthesis processes and indirect electrification replacing conventional hydrocarbons. While part of the heat generated during synthesis can be recovered, for example, for CO<sub>2</sub> capture or space heating, the losses from e-fuel production still represent the largest portion of total energy losses within the system.

### 3.7. Energy system cost and emissions

Energy costs are a key factor in the implementation of ET scenarios. Renewable electricity, along with electricity and heat storage technologies, as well as e-fuels production, are becoming key components for the European energy system and subregions.

The annualised energy system costs peak in 2030 across all scenarios presented and then decrease until 2050. Regarding the **entire region**, in 2030, the cost increases to around 127 b€ in the BPS\_2040 and almost 132 b€ in other scenarios. The BPS\_lowPV presents higher annualised system costs, which increase to 127 b€ by 2035 (see Figure 41 left) and then decrease to 117 b€ by 2050. Costs start to steadily decrease from 2035 as the system transitions to 100% RE by 2050. By 2050,



the total annualised energy system costs in the BPS\_favourOE reach 120 b€, which is around 38% higher than the annualised system cost in 2020. This increase is 36% for the BPS and BPS\_favourVPV, 38% in the BPS\_noBPV, 41% in the BPS\_lowPV, and 44% in the BPS\_2040.

Figure 41 (right) illustrates the evolution of annual capex from 2020 to 2050 across all scenarios for the **entire region**. In general, capex shows a sharp rise during the early transition years, peaking around 2030 before stabilising or declining towards 2050. In the BPS, investments increase steadily, reaching their highest level of 278 b€ in 2035, followed by a decline and moderate recovery to 140 b€ by 2050. A similar pattern appears in the BPS\_noBPV, where capex also peaks at 278 b€ in 2035 and ends at 142 b€ in 2050. The BPS\_lowPV shows a distinct trajectory: after reaching 266 b€ in 2030, investments sharply fall to 82 b€ in 2040 before rising again to 281 b€ in 2050, reflecting the need to deploy more costly technologies once low-cost PV options are exhausted. In the BPS\_favourVPV, capex reaches the highest peak among the scenarios at 322 b€ in 2030, followed by a steady decline to 140 b€ by 2050. Similarly, the BPS\_favourOE sees a peak of 286 b€ in 2030, with a gradual reduction to 141 b€ at the end of the period. Finally, the BPS\_2040 exhibits a unique trend, with investments rising to 396 b€ in 2040, the highest value among all scenarios, before dropping sharply to 58 b€ in 2050.

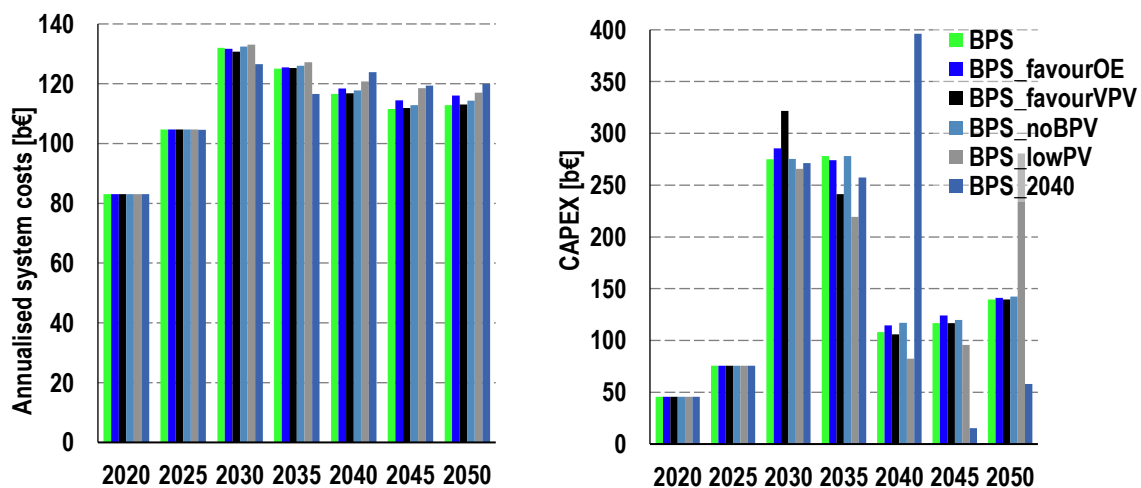

Figure 41 – Annualised energy system costs and capex across the scenarios from 2020 to 2050 for the entire region.

Likewise, Figure 42 indicates the annualised energy system costs and capex in **Ireland** for all scenarios. Figure 42 (left), also presents the annualised system costs for Ireland across scenarios from 2020 to 2050. In the BPS, system costs steadily rise from 6 b€ in 2020 to around 12 b€ by 2040, after which they stabilise. Scenarios with restricted PV deployment, such as the BPS\_noBPV, show a slightly lower cost trajectory, remaining below the baseline by 2050. The BPS\_lowPV case also results in somewhat reduced long-term costs, reflecting lower investment in PV capacity.

In contrast, the BPS\_favourVPV scenario, which prioritises higher vertical PV capacities, leads to substantially higher system costs, peaking at 14 b€ in 2035 before levelling out around 13 b€ towards mid-century. Conversely, the



BPS\_favourOE remains close to the baseline pathway with modestly lower costs in the 2040–2050 period.

A notable deviation appears in the BPS\_2040. Here, annualised system costs sharply increase to 21 b€ in 2040, the highest across all cases, before slightly reducing again by 2050. This reflects the effect of imposing the 2040 system structure across later years. Additionally, Ireland becomes a major e-fuels exporter in the BPS\_2040, with e-FTL and e-methanol exports exceed 97 TWh in 2050 compared to about 53 TWh exported in the BPS 2050, resulting in much higher power generation and e-fuels synthesis capacities and respective costs.

In the BPS\_favourOE, as Figure 42 (right) demonstrates, capex peaks at 36.1 b€ in 2035, reflecting intensive investments during the mid-transition phase towards RE resources and new energy infrastructure. Afterward, capex steadily declines to around 7 b€ by 2050 as the system matures and new installations stabilise. Annualised energy system costs, by contrast, show moderate growth from 6.4 b€ in 2020 to about 10.9 b€ in 2035, before slightly decreasing towards 9.8 b€ by 2050. This pattern suggests that early investments enable long-term operational cost stability, aligning with a maturing, low-carbon, and capital-efficient energy system by mid-century. Differences become more pronounced by 2035 and 2040: in the BPS and BPS\_noBPV capex reach 39 b€ and 37 b€ by 2035, respectively, whereas the BPS\_lowPV records a lower amount of 35 b€, and the BPS\_favourVPV peaks at 47 b€. The most striking deviation in capex occurs in the BPS\_2040, where an accelerated build-out pushes it to 124 b€ in 2040. Towards 2050, capex declines across all scenarios, stabilising at around 13–16 b€, except in the BPS\_2040, where the figure falls sharply to 5 b€.

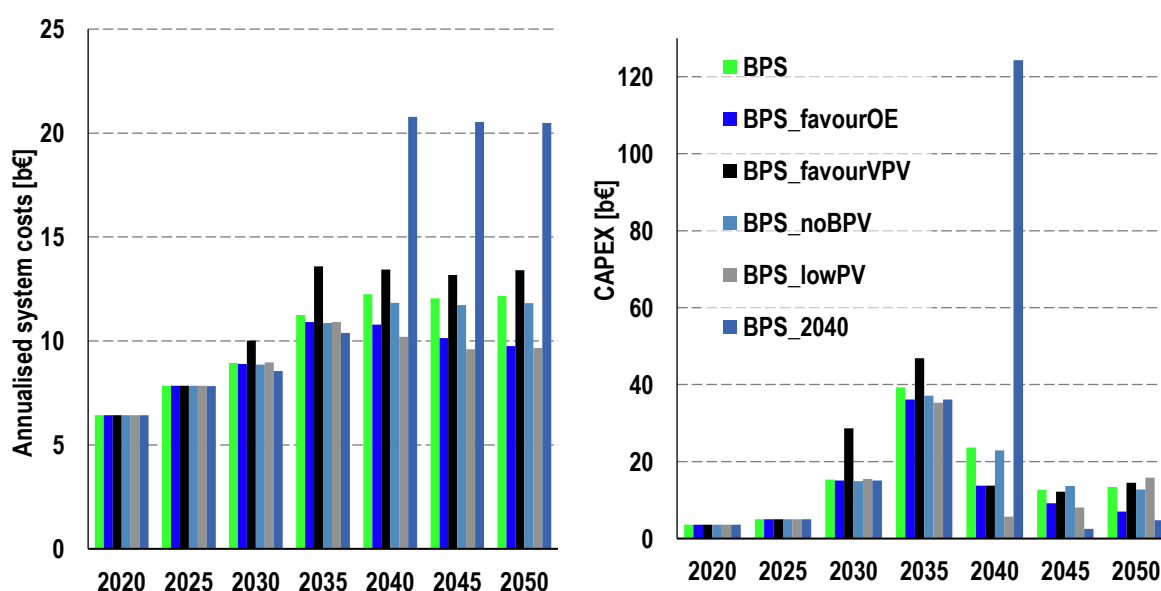

Figure 42 -Ireland annualised system costs and capex in all scenarios.



Overall, investments are most intense between 2025 and 2035, marking the core phase of system transition, while the period 2045–2050 shows declining capex in most cases, indicating system maturity and reduced need for large-scale infrastructure expansion.

When examining cumulative investments between 2020 and 2050, the BPS emerges as the lowest-cost pathway, requiring a total of about 1039 b€ for the **entire region**'s ET. The BPS\_favourOE records slightly higher overall capex of roughly 1061 b€ for the **entire region**, driven by the substantial capital required for ORE technologies, peaking during 2035–2040 but partially compensated by lower storage costs. The BPS\_2040 pathway, characterised by an accelerated ET, shows the highest cumulative capex (about 1119 b€) as rapid early deployment before 2040 necessitates greater upfront funding.

In summary, while scenarios emphasising ORE expansion or accelerated timelines lead to slightly higher investments in the **entire region**, the increase compared to the PV-dominated BPS is not substantial and can be outweighed by other benefits such as a more diversified energy supply portfolio and more stable electricity generation profiles.

For **Ireland**, the BPS\_lowPV and BPS\_favourOE represent the least-cost options, each requiring around 90 b€. The BPS pathway involves total capex of about 113 b€, while the BPS\_noBPV and BPS\_favourVPV require roughly 110 b€ and 124 b€, respectively. The BPS\_2040, driven by an accelerated ET, results in the highest cumulative investment at approximately 191 b€, as substantial early build-out before 2040 demands higher upfront expenditures.

As seen in Figure 43 and Figure 44, the LCOE significantly decreases throughout the transition period. The increasing proportion of renewable power, improved efficiency via sector coupling, and decline in expenditures for fossil fuels along with CO<sub>2</sub> emission costs are the main causes of this decline in LCOE. The overall costs of the system significantly decrease, supported by technological advancements and the declining capex of solar PV and wind power.

As Figure 43 indicates across all scenarios for the **entire region**, the LCOE declines by roughly 57% by 2050 compared to 2020 levels. In the BPS, the LCOE decreases from 93 €/MWh to 37 €/MWh, confirming that renewable electricity is set to become the most cost-competitive energy source. As the transition advances, fuel and CO<sub>2</sub> costs gradually diminish, and from 2040 onward, capex becomes the dominant component of total system costs, while fuel costs turn negative. By 2050, both the BPS and BPS\_favourVPV achieve the lowest LCOE of around 37 €/MWh, outperforming other scenarios. In contrast, the BPS\_favourOE maintains a slightly higher LCOE of 40 €/MWh, while the most accelerated transition scenario records the highest value at approximately 42 €/MWh.

Regarding **Ireland** (see Figure 44), the LCOE drops almost 64% over the transition period and reaches 30 €/MWh in the BPS and 37 €/MWh in the progressive scenario (BPS\_2040). The other scenarios also have the LCOE in this range in 2050



with 32 €/MWh in the BPS\_lowPV and BPS\_favourOE, 31 €/MWh in the BPS\_noBPV, and 34 €/MWh in the BPS\_favourVPV.

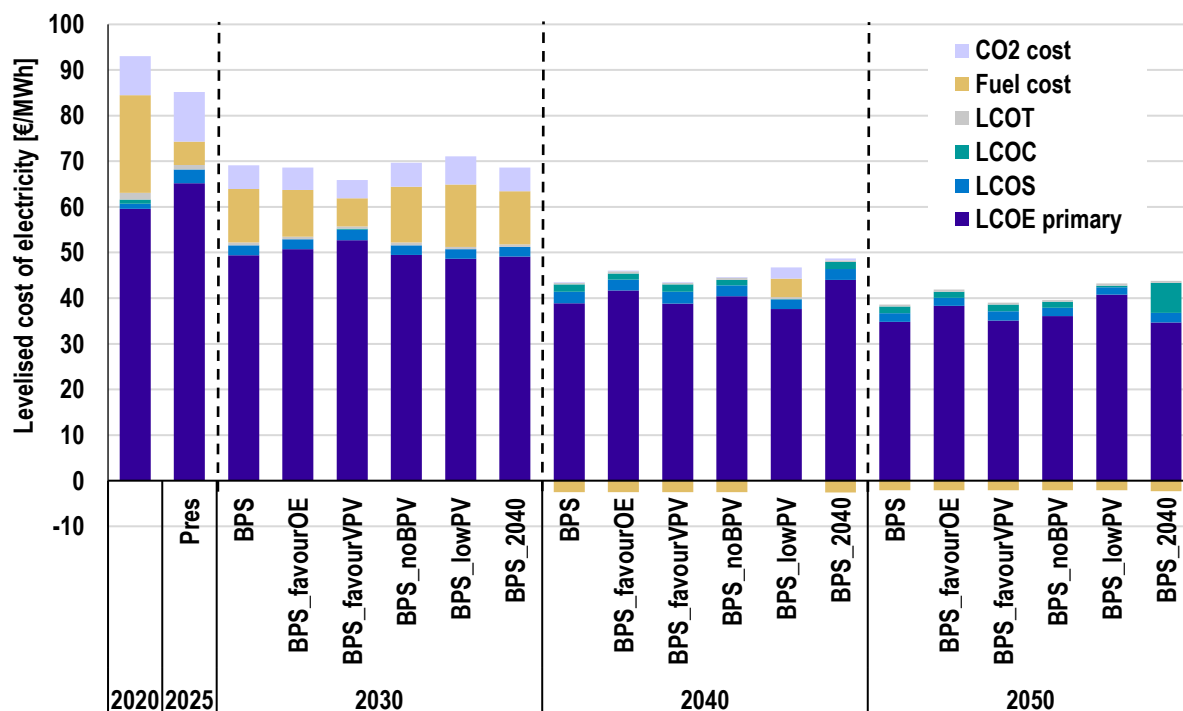

Figure 43 – Levelised cost of electricity (LCOE) for the entire region during the ET.

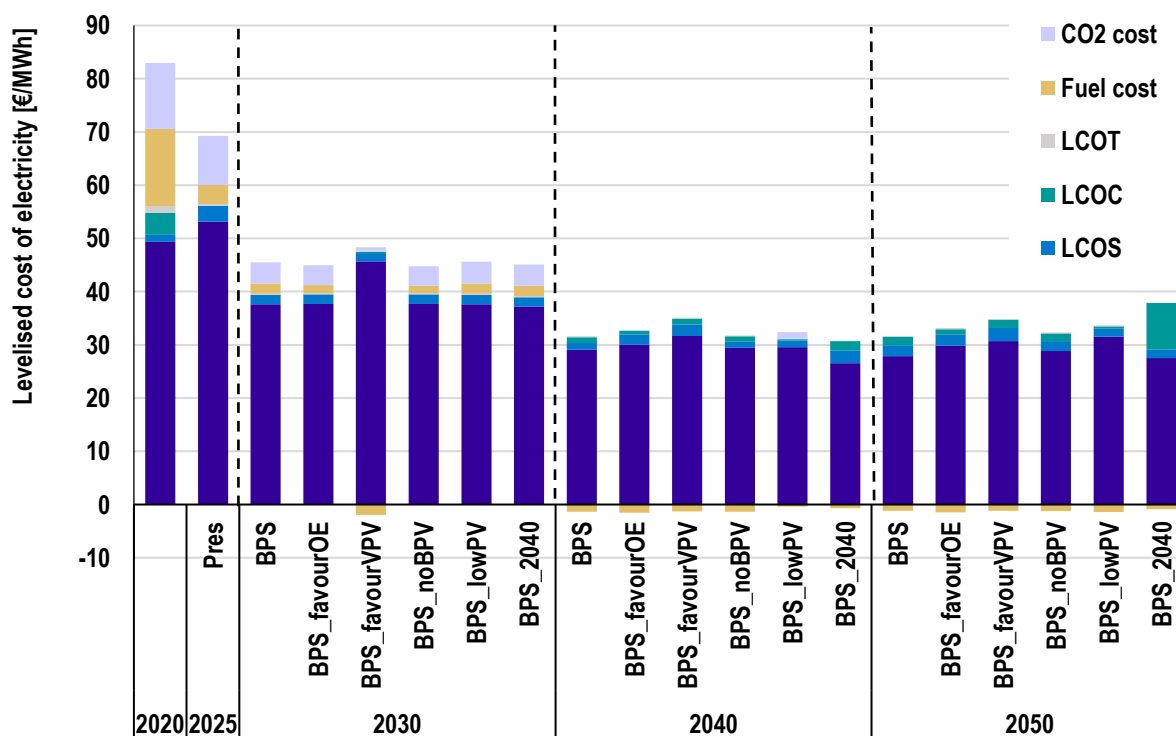

Figure 44 - LCOE for Ireland through all scenarios during the ET.



This project has received funding from the European Union's Horizon 2020 research & innovation programme under grant agreement number 101036457.

The levelised cost of heat (LCOH) and levelised cost of final energy and non-energy use (LCOFE) projections for the **entire region** are shown in Figure 45 and Figure 46. In 2020, the LCOFE stood at almost 47 €/MWh, primarily driven by CO<sub>2</sub> emissions and fuel expenditures. By 2050, the BPS and BPS\_favourVPV reach the lowest systemwide LCOFE, at approximately 67 €/MWh, while the scenario prioritising ORE (BPS\_favourOE) records a slightly higher value of about 69 €/MWh. The accelerated transition scenario (BPS\_2040) exhibits a sharper rise, attaining 76 €/MWh by 2040. Overall, the LCOFE increases by around 147% compared to the 2020 level, with the BPS\_2040 case showing the largest rise of 158%.

Over the long term, capex becomes the main component of LCOFE as fuel expenditures decline, indicating stronger energy independence and security across Europe by 2050. Since LCOFE encompasses all sectors of the energy system, electricity and heat remain the dominant energy carriers. The smaller reduction in LCOFE compared to LCOE or LCOH reflects the higher costs of synthetic e-fuels and e-chemical feedstocks, as e-fuels and e-chemicals remain significantly more expensive than electricity, heat, or today's fossil fuels. This further reinforces the case for direct electrification across all sectors as a most cost-effective and sustainable pathway.

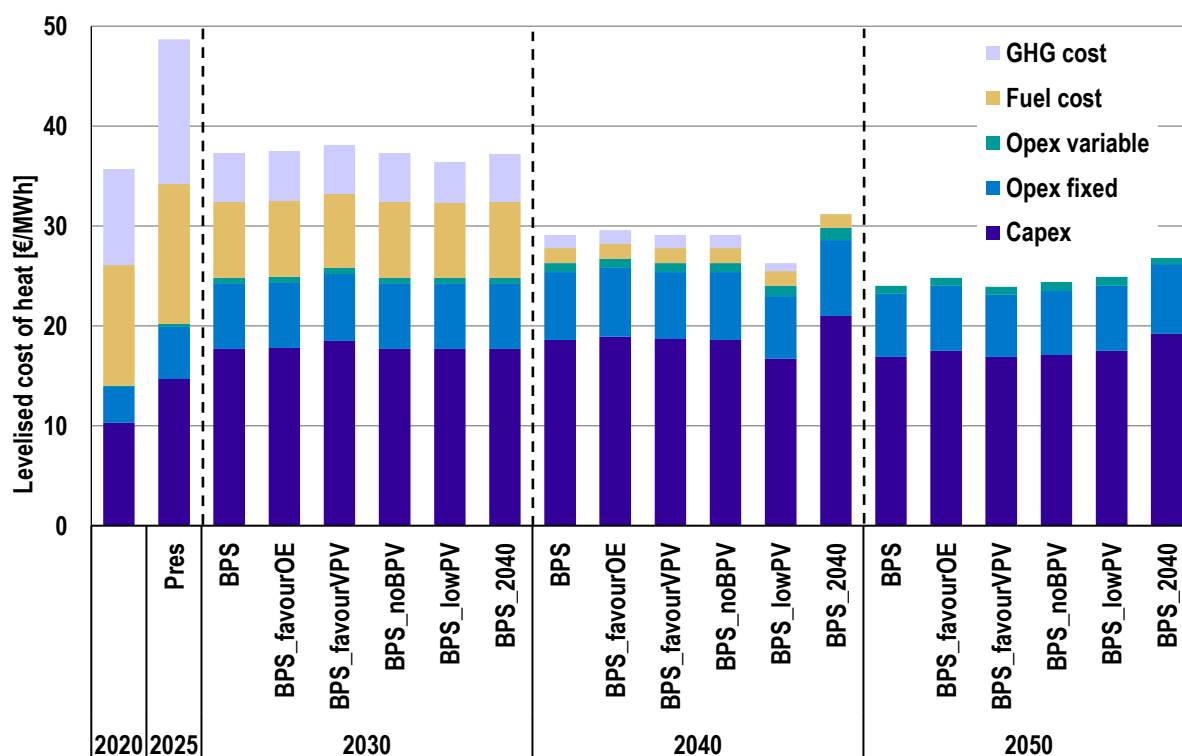

Figure 45 – Levelised cost of heat in the entire region during the ET.



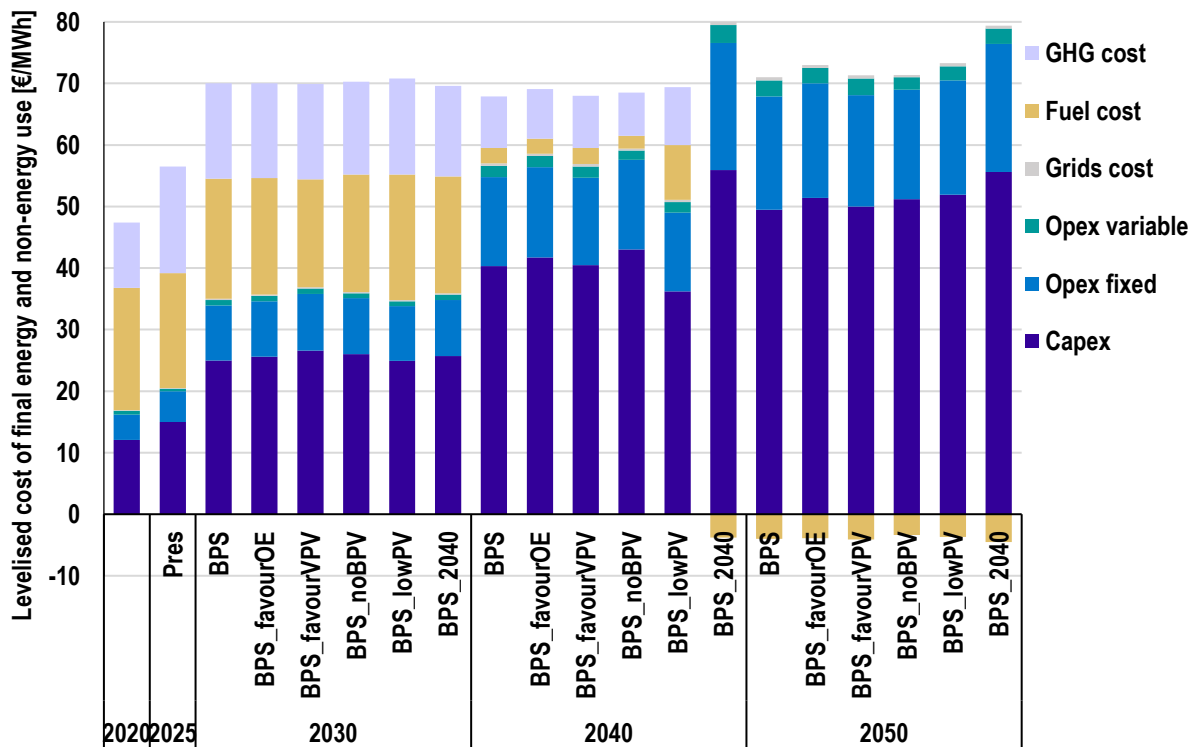

Figure 46 – Levelised cost of final energy and non-energy use during the ET for the entire region.

Figure 47 and Figure 48 present the development of the LCOH and the LCOFE in **Ireland** across all scenarios from 2020 to 2050. Figure 47 shows that LCOH begins at approximately 35 €/MWh in 2020, increasing sharply to around 50 €/MWh by 2025 in most pathways. This rise is driven primarily by higher capex and GHG emissions costs during the ET. By 2030, costs remain clustered around 31–34 €/MWh, with the BPS\_noBPV and BPS\_favourOE reflecting slightly lower values due to more balanced technology deployment. As the energy system moves towards 2040, LCOH noticeably declines across all pathways. LCOH values fall to roughly 24–34 €/MWh in 2040, with the lowest costs observed in the BPS\_lowPV and BPS\_favourOE. The strong reduction in fuel and GHG emissions cost components significantly contributes to this downward trend. The accelerated transition in the BPS\_2040 shows the most distinct shift, reaching cost levels as low as 24–25 €/MWh by 2040 due to rapid early investments. By 2050, LCOH further converges across scenarios, ranging between 17 €/MWh and 27 €/MWh, with fuel components nearly eliminated.

Figure 48 depicts the LCOFE in **Ireland**, which starts at about 50 €/MWh in 2020 before increasing partly slightly to 61–93 €/MWh by 2025, reflecting early investments and fuel cost pressures. By 2030, costs diverge, ranging from 66 €/MWh in the BPS\_lowPV to 71 €/MWh in the BPS\_favourVPV. This divergence becomes more pronounced by 2040; LCOFE varies between 67 €/MWh



(BPS\_lowPV) and over 86 €/MWh (BPS\_2040), driven largely by capex and GHG emissions costs. The long-term picture in 2050 shows the strongest scenario differentiation. In the BPS\_favourOE and BPS\_lowPV, LCOFE stabilises at 61–63 €/MWh, supported by lower capex intensity and reduced grid costs. In contrast, the accelerated transitions (BPS\_2040) reach values well above 93 €/MWh. Though accelerated defossilisation results in slight increase of energy supply cost, as shown for the entire region in Figure 46, the main reason for much higher LCOFE in the BPS\_2040 the high exports of e-fuels from **Ireland** and, consequently, a high share of high-cost e-fuels compared to low-cost electricity in the energy mix.

In 2050, scenarios show negative fuel costs, which reflect the high share of renewable electricity and e-fuels produced within the system. These negative values represent situations where it is attractive for the integrated energy system of **Ireland and the UK** to produce e-fuels in Ireland to be used in the entire region, effectively reducing the net cost of energy supply for the **entire region**. However, this reduction is accompanied by substantially higher capex, grid costs, and fixed opex. These additional costs arise from the large-scale infrastructure required to enable a high RE penetration, such as expanded electricity grids, storage systems, and conversion technologies. As a result, even though fuel costs fall below zero, the overall system cost remains elevated due to the substantial capex and fixed opex.

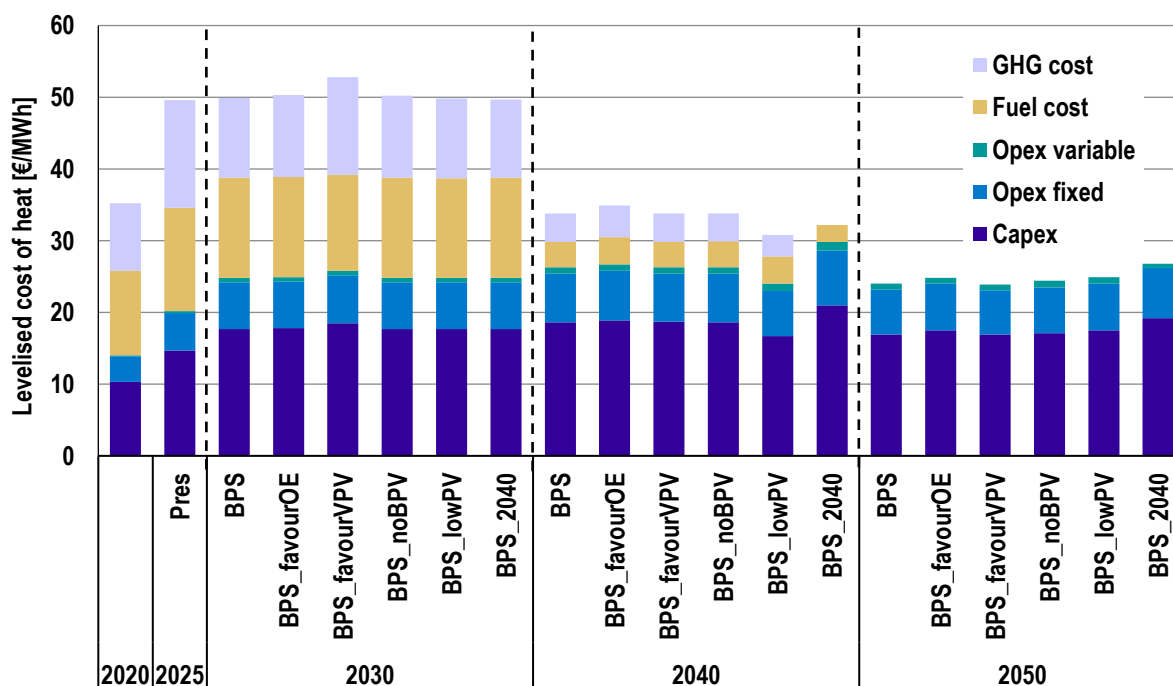

Figure 47- Levelised cost of heat during the ET in Ireland.



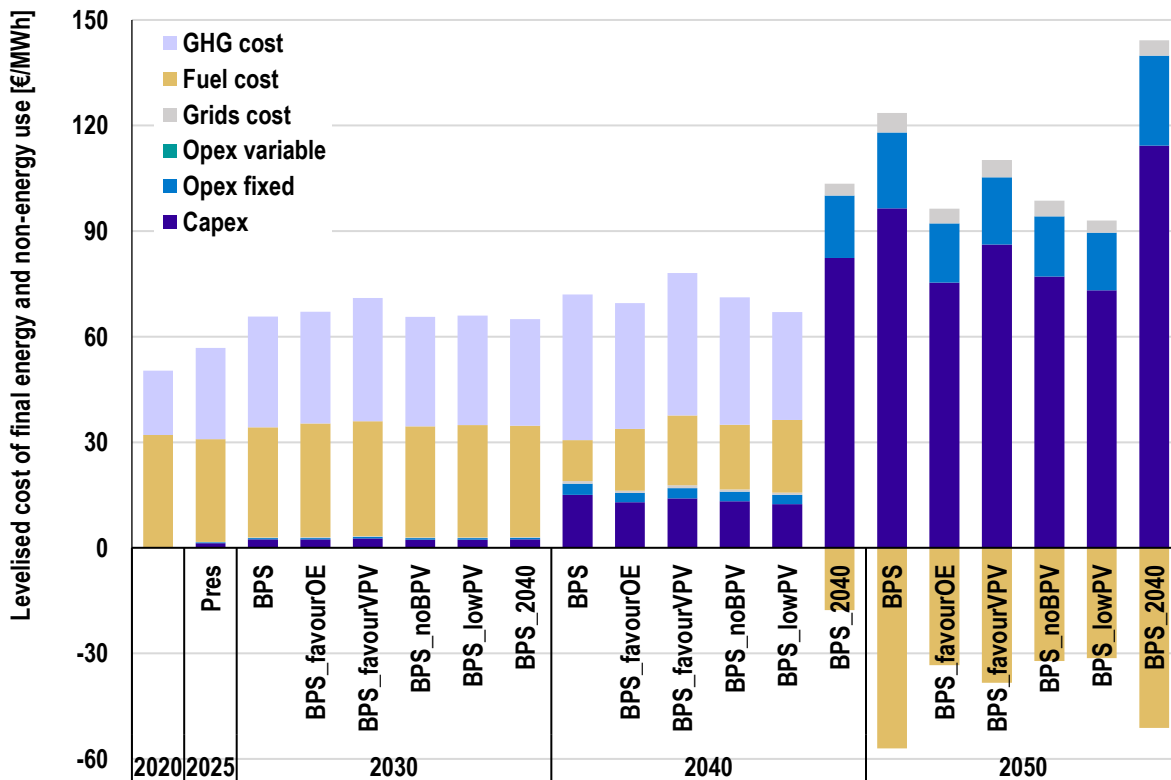

Figure 48 - Levelised cost of final energy and non-energy use during the ET in Ireland.

The results of the ET scenarios demonstrate a sharp decline in CO<sub>2</sub> emissions across the power, heat, transport, and industry sectors in all six scenarios by 2050, as shown in Figure 49 (for **entire region**) and Figure 50 (for **Ireland**). In 2020, CO<sub>2</sub> emissions from the power sector were around 7 MtCO<sub>2</sub> for **Ireland** and 52 MtCO<sub>2</sub> for the **entire region**; however, they experience a rapid decrease to zero by 2040 in the BPS\_2040 and by 2050 in other scenarios. The transport sector, which accounts for the highest emissions in 2020 of around 16 MtCO<sub>2</sub> and 183 MtCO<sub>2</sub> for **Ireland** and **entire region**, respectively, declines rapidly by 2040, though it is the dominant sector in emissions. Nevertheless, the transport sector does achieve zero emissions by 2050. The lowest emissions in 2030 occur in the BPS\_favourVPV. In other scenarios, emissions from the transport and industry sectors persist but remain minimal. In 2040, the BPS\_lowPV records more than double the emissions compared to other cases, indicating that with limited solar PV deployment, the energy system continues to experience significantly higher CO<sub>2</sub> emissions resulting in the highest cumulative emissions (Figure 51 and Figure 52). Overall, emissions across all sectors experience an accelerated reduction to zero by 2040 in the progressive scenario, and a steady decline to zero by 2050 in other scenarios. Figure 51 and Figure 52 present the cumulative TTW CO<sub>2</sub> emissions in all the scenarios by 2050 for the **entire region** and **Ireland**, respectively.



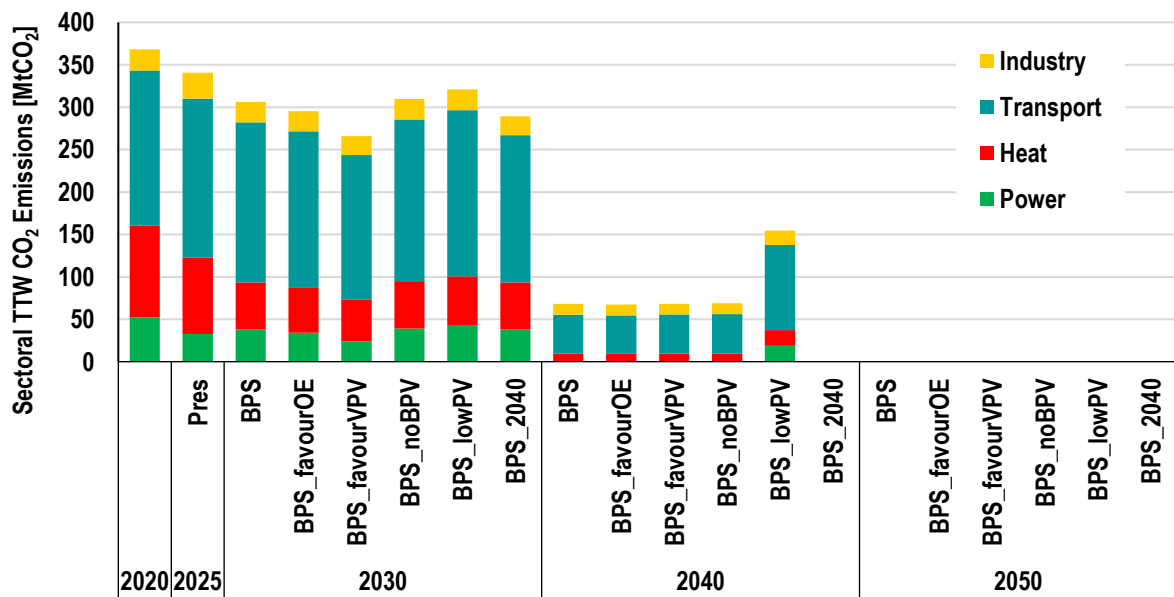

Figure 49 – Sectoral annual CO<sub>2</sub> emissions in all scenarios during the ET for the entire region.

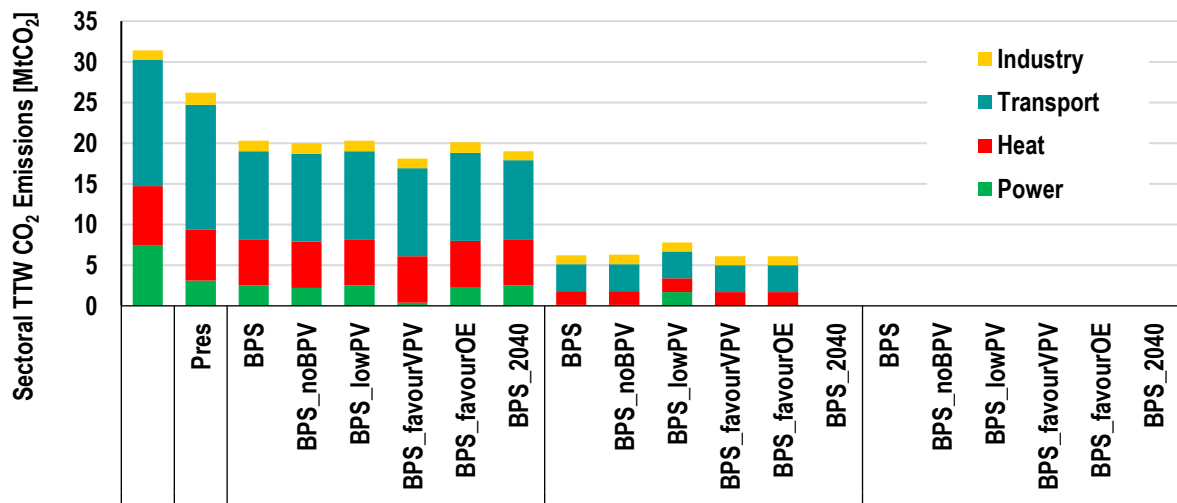

Figure 50 – Sectoral annual CO<sub>2</sub> emissions for Ireland in all scenarios during the ET.



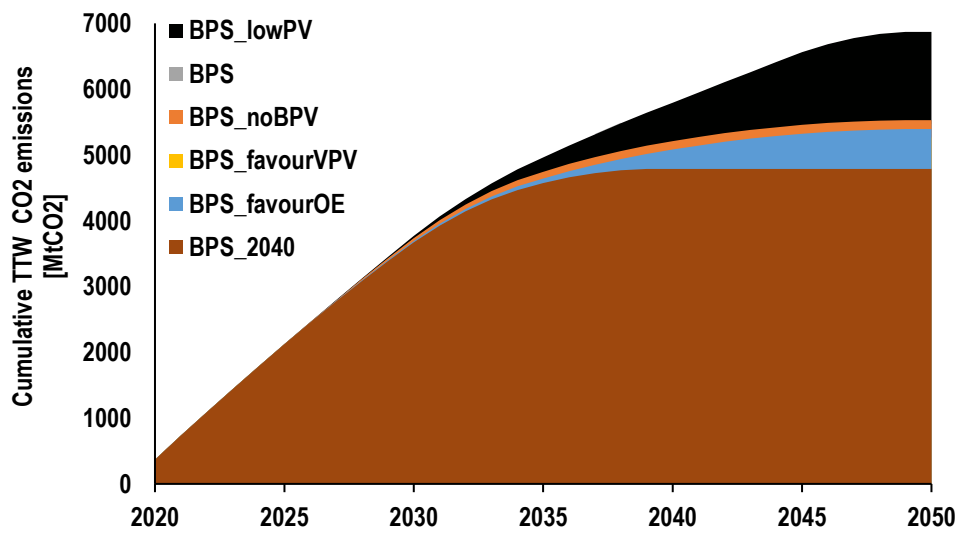

Figure 51 - Cumulative TTW CO<sub>2</sub> emissions in all scenarios during the ET in the entire region.

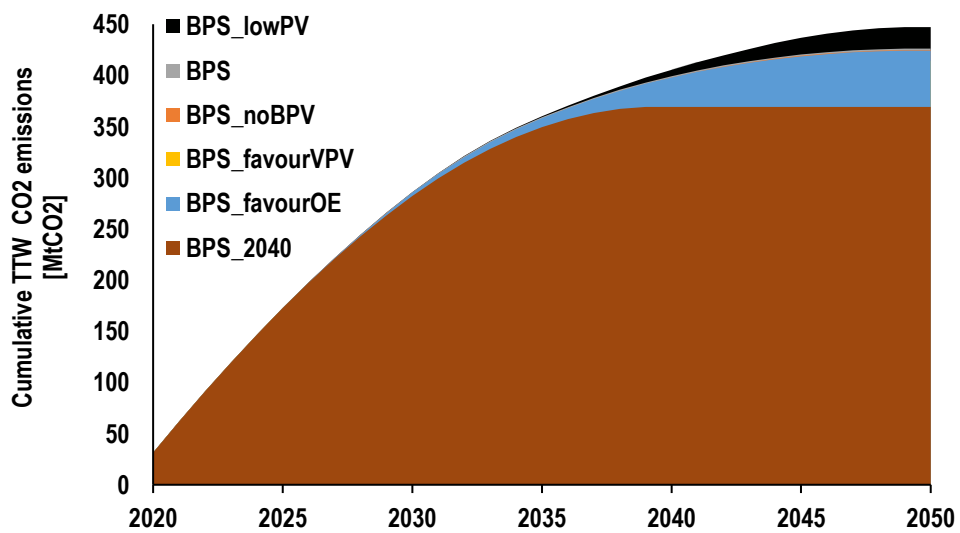

Figure 52 - Cumulative TTW CO<sub>2</sub> emissions for Ireland in all scenarios during the ET.



## 4. Complementary impacts

### 4.1. The role of offshore renewable energy in achieving the energy targets of Ireland and the UK

The integration of ORE into the energy system is particularly vital for regions such as **Ireland and the UK**, where densely populated and highly developed urban areas, such as London, limit land availability for large-scale onshore RE installations. Considering the constraints discussed in [28], limited land resources in **Ireland and the UK** highlight the potential of ORE technologies to play a crucial role in achieving energy system defossilisation. Offshore wind power and wave power offer abundant RE potential along the extensive coastlines of both countries, supporting the transition to a resilient and fossil free energy mix. Furthermore, when onshore land is scarce or faces competing demands from agriculture, urban development, or biodiversity needs, OSPV can contribute a considerable share of total solar PV electricity generation at only marginally higher costs, providing a flexible and area-efficient complement to offshore wind power [50]. In this context, the strategic deployment of ORE around the regions helps alleviate spatial limitations and strengthens energy security, enhances system flexibility, and supports progress towards the net-zero emission targets of both **Ireland and the UK**.

In the BPS\_favourOE for **Ireland and the UK**, the integration of ORE technologies was promoted to address spatial and energy challenges in densely populated regions. A major difficulty arose in London, where limited land availability and restricted access to coastal areas severely confined the deployment of RE technologies and electrolyzers. Since each subregion in the model was required to be self-sufficient across all energy sectors, London's inability to host sufficient RE necessitated the creation of a shared e-fuel and e-chemical production pool with the England South and England East regions.

To ensure adequate electricity supply, the transmission grid growth rate for lines connecting London was increased from 25% to 50% per five-year period, enabling larger power inflows from surrounding regions. Additionally, the ORE resource usage was raised to 50% of its technical potential, allowing offshore wind power, wave power, and OSPV to substantially contribute to London's energy demand. These adjustments highlight the essential role of ORE and strengthened transmission infrastructure in supporting energy self-sufficiency and defossilisation and avoid installing nuclear power plants in densely populated areas such as London, reinforcing their importance in achieving the **UK's** and in general the **entire region's** net-zero goals.

The analysis of the BPS results reveals that in the cost-optimised scenario, ORE accounts for only 3.3% of the total energy mix, with no contribution from OSPV. In contrast, the BPS\_favourOE achieves a notably higher ORE share of 8.3%, including approximately 19.1 GW of OSPV capacity. Despite this expansion, the overall system costs rise by no more than 2.3% by 2050 compared to the baseline BPS configuration, indicating that favouring ORE development leads to a more



sustainable, diversified, and resilient energy system without significantly compromising economic efficiency.

The inclusion of wave power in the energy supply improves power output stability, reduces periods of energy shortfall, and enhances the complementarity of the RE mix [63]. By complementing the temporal variability of solar PV, particularly during the winter months when solar irradiation is low and electricity demand is elevated, ORE technologies, especially wave power, play a crucial role in smoothing power generation and reducing reliance on electricity storage and hydrogen balancing. Similar synergies between wave power and solar PV generation have been highlighted by Jin and Greaves [64], Satymov et al. [30], and in regional studies such as Seychelles [65], Iberia [66], New Zealand [67], and Hawaii [28], all of which confirm wave power's potential to enhance the stability of RE-based systems through its seasonal complementarity. This behaviour is further supported by Keiner et al. [31], who demonstrated in the Maldives context that wave power can effectively complement solar PV during periods of reduced solar availability.

In the case of **Ireland and the UK**, this complementarity is particularly advantageous, as both regions experience significant seasonal variations in solar resources. Integrating wave power into the RE portfolio helps to maintain a consistent supply throughout the year, lowers the need for large-scale energy storage, and strengthens overall system reliability. Consequently, the inclusion of ORE represents a cost-effective and strategic pathway to achieve a stable and balanced ET.

In the close focus of **Ireland's** energy system, the integration of ORE is essential given its vast ORE potential and limited availability of land for large-scale onshore RE installations, as already identified by Diesing et al. [19]. In the BPS\_favourOE, the strategic expansion of ORE including offshore wind power, wave power, and OSPV, addresses spatial and energy challenges while strengthening grid flexibility and energy security. Renewable electricity becomes the dominant source, increasing from 13 TWh in 2020 to 234 TWh in 2050, as fossil fuels are almost completely phased out. Correspondingly, the installed power capacity rises from 10 GW to 123 GW, led by onshore solar PV (89 GW) and onshore wind power (24 GW), while storage technologies expand from 2 GWh to 67 GWh, driven largely by V2G systems. Electricity generation follows a similar pattern, reaching 236 TWh by 2050, with RE, particularly solar PV and wind power, fully replacing fossil fuel-based electricity generation. These developments indicate a large-scale shift toward a flexible, RE-based power system supported by ORE resources, distributed storage, and strengthened transmission capacity.

## 4.2. The role of technological diversity in achieving the energy targets of Ireland and the UK

The comparison between the BPS, BPS\_favourOE, and other scenarios that impose restrictions or changes to solar PV deployment highlight the important role of PV technologies in the region's transition. The BPS\_lowPV, which limits the expansion



This project has received funding from the European Union's Horizon 2020 research & innovation programme under grant agreement number 101036457.

of solar PV systems, results in lower system costs during the transition but compensates this in 2050 by a 293% increase in capex compared to 2045. For the **entire region**, the cumulative capex in the BPS, at 1039 b€ (of which 113 b€ for **Ireland**), is the lowest among all scenarios, while in the BPS\_favourOE it remains only slightly higher at 1061 b€ (90 b€ of which relates to **Ireland**). A main reason is a reduction in electricity storage capacity, leading to a more balanced intraday generation profile and reducing grid use, curtailment, (see Figure 53) and peak transmission loads. These results show that while technology diversity alone does not lead to drastic cost reductions, it contributes to greater system flexibility [68], which eases land-use pressures and reduces curtailment by improving the match between electricity generation and demand profiles.

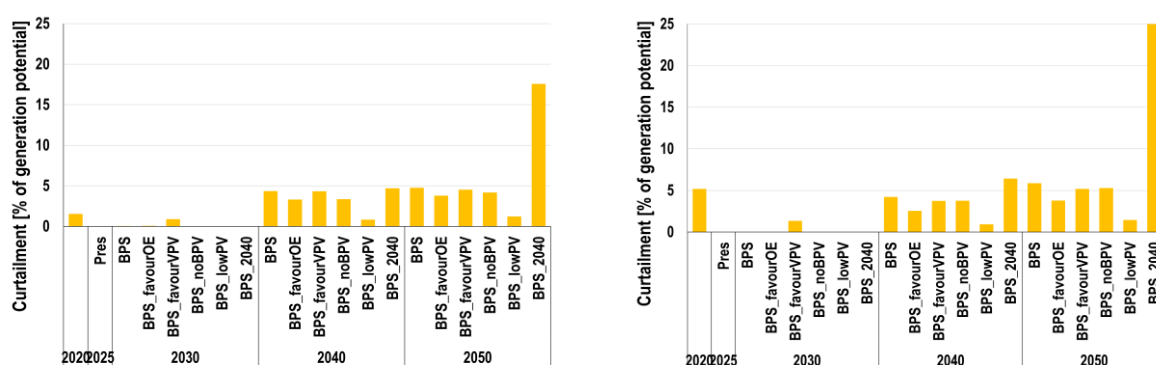

Figure 53 - Electricity curtailment over the ET across all scenarios during the ET in the entire region (left) and Ireland (right).

OSPv, although currently more expensive than land-based PV systems, is becoming increasingly viable in scenarios and will become a key power generation technology in the future in regions where land availability is limited [65,69]. The reduction in ground-mounted PV deployment led to a compensating increase in installed wave power capacity in the BPS\_lowPV, and higher reliance on batteries and hydrogen storage in the BPS\_noBPV. This outcome led to higher system costs. On the other hand, considerably lower curtailment, highlighting the system value of combined benefits of PV diversity and spatial deployment, which helps to smoothen the electricity generation profile and reduce the need for additional balancing capacity. Vertical PV systems have a minor impact on the total solar PV capacity [49]. In the progressive scenario (BPS\_2040), because of early defossilisation by 2040, the system has a significant amount of curtailment losses, which has a large impact on the overall cumulative cost and keeps the LCOFE higher compared to other scenarios.

Considering **Ireland's** energy demand in different sectors, the FED in **Ireland** moderately rises from 18.7 TWh in 2020 to 20.4 TWh in 2050, with electrification emerging as a central trend across all sectors. Heat demand peaks near 39 TWh in 2035 and slightly declines thereafter due to efficiency gains, while transport demand drops from 60 TWh to 46 TWh as electric mobility expands. Industrial



demand grows from 15.4 to about 26 TWh, reflecting steady economic and electrification-driven growth. The heat sector undergoes a comprehensive transition, as heat pumps become the dominant technology (6 GW, 37 TWh by 2050), while fossil gas and oil are phased out. Complementing this, hydrogen-based storage expands rapidly from zero to 27 TWh, providing essential seasonal balancing. In the transport sector, road FED declines sharply as aviation FED grows to become the main consumer, increasing from 10.7 to 27.5 TWh. Fuel conversion capacity also transitions towards e-fuels, with electrolyzers reaching nearly 27 GW by 2050, supported by Fischer–Tropsch, e-methanol, and e-ammonia. Finally, capex peaks at 36 b€ in 2035, reflecting intensive investments in RE and hydrogen infrastructure, before stabilising near 7 b€ by 2050. This trajectory demonstrates how early, large-scale investments in ORE, electrification, and storage lay the foundation for a mature, cost-efficient, and fully defossilised energy-industry system in **Ireland** by mid-century.



This project has received funding from the European Union's Horizon 2020 research & innovation programme under grant agreement number 101036457.

## 5. Summary and key messages

This report examines the projected evolution of the Republic of **Ireland** and the **United Kingdom**'s energy systems between 2020 and 2050 through several scenarios, focusing on the influence of offshore renewable energy expansion and solar photovoltaics diversification on sectoral defossilisation pathways and greenhouse gas reduction. A key outcome of the analysis is the consistent and substantial decline in final energy demand, which decreases by around 5% in most scenarios relative to 2020, and by nearly 9% compared to 2025, even as economic and industrial activity continues to grow, particularly in the transport and industry sectors. These reductions are mainly attributed to advances in energy efficiency, energy system electrification, and the integration of smart energy technologies. Notably, the BPS\_2040 scenario delivers the most pronounced decline in energy consumption, approximately 14% lower than 2025 levels, reflecting the effects of stronger policy measures, faster technological adoption, and early progress towards a more efficient and sustainable energy system.

A higher level of electrification, the integration of smart energy technologies, combined with a shift towards renewable energy sources, leads to a restructuring of primary energy demand. In 2020, fossil fuels dominate the energy supply mix, while by 2050, renewable electricity becomes the principal energy source in all scenarios. This transition results in primary energy demand rising from 2186 TWh to 2588 TWh (for the **entire region**) and 163 TWh to 317 TWh (for **Ireland**) in the baseline BPS and to 2670 TWh (for the **entire region**) and 504 TWh (for **Ireland**) in the most ambitious scenario, mostly due to rising production of e-fuels and e-chemicals for transport and industrial use. Integration of offshore renewable energy technologies contributes to overall system efficiency allowing the system to reduce the primary energy demand compared to the BPS.

The electrification of the energy system requires a rapid increase in power generation capacity. Over the analysed period for the **entire region**, installed capacities sharply expand from about 110 GW in 2020 to 355 GW in 2030, and nearly 1519 GW by 2050 in the BPS, in **Ireland** the installed capacity increases from 10.5 GW to 191 GW in the BPS and 122 GW in the BPS\_favourOE. Solar photovoltaics and wind power emerge as the leading generation technologies, with solar photovoltaics capacity ranging between 770 GW and 1412 GW and producing between 893 and 1585 TWh of electricity across the scenarios. **Ireland**'s energy system follows the same pattern with solar photovoltaics capacity spanning 61–323 GW<sub>p</sub> and generating approximately 65–360 TWh of electricity across the scenarios. Offshore wind power becomes increasingly important, particularly in the offshore renewable energy favouring scenario, reaching 38 GW of capacity and up to 200 TWh of generation. Nuclear power is phased out by 2040, and fossil fuel-based electricity generation dramatically declines across all scenarios, falling close to zero by 2040, except in the low solar photovoltaics scenario, where a small fossil fuel share remains temporarily before disappearing by mid-century.

Electricity storage systems rapidly expand to manage the variability of renewable electricity generation. By 2050, small-scale, prosumers batteries exceed 132 TWh of



output, providing crucial system flexibility, followed by utility-scale batteries, which deliver between 15 and 25 TWh depending on the scenario. Scenarios with greater solar photovoltaics deployment rely less on storage, requiring about 142 TWh, while the most progressive BPS\_2040 scenario reaches 171 TWh. Across all cases, vehicle-to-grid batteries and pumped hydro energy storage play minor but supportive roles, complementing the main battery systems.

The industry sector experiences moderate overall growth in energy demand, mainly driven by the expansion of the chemical and aluminium industries as the steel and cement industries decline as a result of improved material efficiency and substitution. In the transport sector, energy consumption for road transportation significantly decreases with the widespread adoption of electric vehicles and aviation becomes the largest single transport energy consumer by 2050 due to its limited electrification potential. To supply sustainable fuels for industry, aviation, and shipping, the production capacity for synthetic e-fuels and e-chemicals, particularly hydrogen electrolyzers, expands from nearly zero in 2020 to more than 493 GW<sub>el</sub> by 2050, accompanied by steady growth in e-methanol and Fischer–Tropsch e-fuel synthesis. **Ireland** alone demands 66 GW<sub>el</sub> electrolyser capacity by 2050 in the BPS, but the introduction of offshore renewable energy in the BPS\_favourOE or BPS\_lowPV allows the system to benefit from more stable renewable electricity generation profiles, which reduces electrolyzers capacity to 40 GW<sub>el</sub> and 33 GW<sub>el</sub>, respectively.

The findings of this study demonstrate that integrating offshore wind power, floating offshore solar photovoltaics, and wave power into the energy systems of **Ireland** and the **United Kingdom** does not result in major increases in total system costs compared with scenarios with lower shares of these technologies. Furthermore, such systems can provide clear benefits in terms of system diversity and resilience. Conversely, scenarios with lower solar photovoltaics capacity prove to be the most expensive, underlining the economic importance of maintaining a strong solar photovoltaics component in the generation mix. By 2050, the scenario favouring offshore renewable energy has cumulative annualised system costs of around 1061 b€, while the low solar photovoltaics scenario reaches 1066 b€, about 5 b€ higher than the BPS. The levelised cost of electricity follows a similar trend, rising from 37 €/MWh in the baseline BPS to 42 €/MWh in the favouring offshore renewable energy scenario. Offshore renewable energy also enhances system stability, as reflected by a 2.5% reduction in electricity storage requirements in 2050 (from 157 TWh in the BPS to 153 TWh in the BPS\_favourOE). This indicates lower dependence on long-term fuel storage and balancing, reduced operational risks, and greater security of supply in a system dominated by variable renewable energy sources.

Important to note, test scenario runs performed during the scenario framing showed that the onshore RE potential is not enough to build self-sufficient sustainable energy system without OE use. In general, while scenarios that prioritise offshore renewable energy and floating offshore solar photovoltaics technologies entail slightly higher capital expenditures and system costs, they yield a more robust, regionally balanced, and efficient energy architecture. These



This project has received funding from the European Union's Horizon 2020 research & innovation programme under grant agreement number 101036457.

results advocate for a strategic transition towards greater technological diversity in offshore renewable energy as a central driver of a sustainable and secure energy future for **Ireland** and the **United Kingdom**.

Particularly in the case of **Ireland**, where the BPS\_favourOE illustrates a comprehensive and balanced pathway towards full defossilisation. Renewable electricity generation expands from just 13 TWh in 2020 to 234 TWh in 2050, completely replacing fossil fuel-based energy sources. Installed capacity increases more than tenfold, led by onshore solar photovoltaics and onshore wind power, while floating offshore solar photovoltaics and wave power emerge as complementary technologies after 2040. Electrification becomes the cornerstone of the energy transition in **Ireland**, with heat pumps and electric heating replacing gas and oil systems, and transport shifting rapidly towards electric and low-carbon modes. Hydrogen production and storage also substantially scale up, enabling seasonal balancing and supporting renewable e-fuel synthesis for hard-to-abate segments, such as aviation, marine transportation, and industry. Although investment requirements peak mid-transition, operational costs stabilise towards 2050, confirming that early, targeted investments in offshore renewable energy, electrification, and hydrogen infrastructure lay the groundwork for long-term economic efficiency and system resilience.

In summary, the evidence from both **Ireland** and the **United Kingdom** underscores that the integration of offshore renewable energy, together with advanced electrification and storage, offers a cost-effective route to net-zero greenhouse gas emissions and a more secure and regionally equitable energy framework. The complementarity between solar photovoltaics, wind power, and wave power ensures greater year-round reliability, reducing dependence on large-scale storage and imported fuels. Technological diversity across offshore renewable energy and solar photovoltaics systems enhances flexibility, minimises curtailment, and lowers grid stress, all while maintaining competitive energy costs. These findings affirm that prioritising offshore renewable energy expansion, coupled with hydrogen and power-to-X technologies, is essential to achieving a resilient, efficient, and fully defossilised energy system across **Ireland** and the **United Kingdom** by mid-century.



## 6. References

- [1] [NOAA] - National Oceanic and Atmospheric Administration, “National Centers for Environmental Information, Monthly Global Climate Report for Annual 2024,” Washington, D.C., 2025. [Online]. Available: <https://www.ncei.noaa.gov/access/metadata/landing-page/bin/iso?id=gov.noaa.ncdc:C00672>
- [2] [WMO] - World Meteorological Organisation, “State of the Global Climate 2024 (WMO-No. 1368),” Geneva, 2025. [Online]. Available: <https://wmo.int/publication-series/state-of-global-climate-2024>
- [3] [EEA] - European Environmental Agency, “Europe’s changing climate hazards — an index-based interactive EEA report,” Copenhagen, 2023. doi: 10.2800/458052.
- [4] Copernicus Climate Change Service (C3S) and World Meteorological Organization (WMO), “European State of the Climate 2024,” Geneva, 2025. [Online]. Available: [doi.org/10.24381/14j9-s541](https://doi.org/10.24381/14j9-s541)
- [5] [IPCC] - Intergovernmental Panel on Climate Change, “Renewable Energy Sources and Climate Change Mitigation — IPCC,” Geneva, 2011. [Online]. Available: <https://www.ipcc.ch/report/renewable-energy-sources-and-climate-change-mitigation/>
- [6] [EC] - European Commission, “The European Green Deal,” Brussels, 2019. [Online]. Available: [https://ec.europa.eu/info/sites/info/files/european-green-deal-communication\\_en.pdf](https://ec.europa.eu/info/sites/info/files/european-green-deal-communication_en.pdf)
- [7] [UNFCCC] - United Nations Framework Convention on Climate Change, “Adoption of Paris Agreement. Proposal by the President,” Bonn, 2015. [Online]. Available: <https://unfccc.int/documents/184656>
- [8] [EC] - European Commission, “Technology pathways in decarbonisation scenarios,” Brussels, 2025. [Online]. Available: <https://op.europa.eu/en/publication-detail/-/publication/599a1d8e-509a-11eb-b59f-01aa75ed71a1/language-en>
- [9] [EC] - European Commission, “Renewable Energy Directive,” Brussels, 2025. [Online]. Available: <https://eur-lex.europa.eu/eli/dir/2023/2413/oj>
- [10] [NREL] - National Renewable Energy Laboratory, “International Applications for Floating Solar Photovoltaics,” Golden, CO (United States), 2019. doi: 10.2172/1526906.
- [11] D. Bogdanov et al., “Low-cost renewable electricity as the key driver of the global energy transition towards sustainability,” *Energy*, vol. 227, p. 120467, 2021, doi: 10.1016/j.energy.2021.120467.



- [12] M. Z. Jacobson et al., “Impacts of Green New Deal Energy Plans on Grid Stability, Costs, Jobs, Health, and Climate in 143 Countries,” *One Earth*, vol. 1, no. 4, pp. 449–463, 2019, doi: 10.1016/j.oneear.2019.12.003.
- [13] S. Teske et al., “It Is Still Possible to Achieve the Paris Climate Agreement: Regional, Sectoral, and Land-Use Pathways,” *Energies*, vol. 14, no. 8, p. 2103, 2021, doi: 10.3390/en14082103.
- [14] G. Luderer et al., “Impact of declining renewable energy costs on electrification in low-emission scenarios,” *Nat Energy*, vol. 7, no. 1, pp. 32–42, 2021, doi: 10.1038/s41560-021-00937-z.
- [15] A. Ahmad, N. Power, and E. Finegan, “Maximising solar PV potential: A comprehensive review of factors affecting photovoltaic installation and generation in a mild temperate oceanic climate,” *Solar Energy Advances*, vol. 5, p. 100111, 2025, doi: 10.1016/j.seja.2025.100111.
- [16] B. Johnston, D. Al Kez, S. McLoone, and A. Foley, “Offshore wind potential in Northern Ireland using GIS multi-criteria assessment,” *Appl Energy*, vol. 378, p. 124764, 2025, doi: 10.1016/j.apenergy.2024.124764.
- [17] H. A. Said, A. Skiarski, and J. V. Ringwood, “Combined renewable resource exploitation: Implications for the all-island Irish electricity supply system,” *Energy Conversion and Management: X*, vol. 26, p. 100992, 2025, doi: 10.1016/j.ecmx.2025.100992.
- [18] S. Abdelaziz, S. N. Sparrow, W. Hua, and D. C. H. Wallom, “Assessing the long-term effects of climate change on offshore wind operations in the UK,” *Energy*, vol. 332, p. 137062, 2025, doi: 10.1016/j.energy.2025.137062.
- [19] P. Diesing, D. Bogdanov, R. Satymov, M. Child, I. Hauer, and C. Breyer, “Offshore versus onshore: The underestimated impact of onshore wind and solar photovoltaics for the energy transition of the British Isles,” *IET Renewable Power Generation*, vol. 17, no. 13, pp. 3240–3266, 2023, doi: 10.1049/rpg2.12840.
- [20] C. Breyer et al., “On the role of solar photovoltaics in global energy transition scenarios,” *Progress in Photovoltaics: Research and Applications*, vol. 25, no. 8, pp. 727–745, 2017, doi: 10.1002/pip.2885.
- [21] N. M. Haegel et al., “Photovoltaics at multi-terawatt scale: Waiting is not an option,” *Science (1979)*, vol. 380, no. 6640, pp. 39–42, 2023, doi: 10.1126/science.adf6957.
- [22] C. Breyer et al., “Reflecting the energy transition from a European perspective and in the global context—Relevance of solar photovoltaics benchmarking two ambitious scenarios,” *Progress in Photovoltaics: Research and Applications*, vol. 31, no. 12, pp. 1369–1395, 2023, doi: 10.1002/pip.3659.
- [23] D. Bogdanov, A. Gulagi, M. Fasihi, and C. Breyer, “Full energy sector transition towards 100% renewable energy supply: Integrating power, heat, transport



- and industry sectors including desalination,” *Appl Energy*, vol. 283, p. 116273, 2021, doi: 10.1016/j.apenergy.2020.116273.
- [24] M. Sterner and M. Specht, “Power-to-Gas and Power-to-X—The History and Results of Developing a New Storage Concept,” *Energies*, vol. 14, no. 20, p. 6594, 2021, doi: 10.3390/en14206594.
- [25] S. Khalili, G. Lopez, and C. Breyer, “Role and trends of flexibility options in 100% renewable energy system analyses towards the Power-to-X Economy,” *Renewable and Sustainable Energy Reviews*, vol. 212, p. 115383, 2025, doi: 10.1016/j.rser.2025.115383.
- [26] D. Bogdanov et al., “Costs and benefits of highly ambitious energy transition pathways for Europe,” *Energy*, vol. 336, p. 138477, 2025, doi: 10.1016/j.energy.2025.138477.
- [27] M. Victoria, K. Zhu, T. Brown, G. B. Andresen, and M. Greiner, “Early decarbonisation of the European energy system pays off,” *Nat Commun*, vol. 11, no. 1, p. 6223, 2020, doi: 10.1038/s41467-020-20015-4.
- [28] G. Lopez, R. Satymov, A. Aghahosseini, D. Bogdanov, A. S. Oyewo, and C. Breyer, “Ocean energy enabling a sustainable energy-industry transition for Hawai’i,” *Renew Energy*, vol. 237, p. 121831, 2024, doi: 10.1016/j.renene.2024.121831.
- [29] R. Satymov, D. Bogdanov, and C. Breyer, “Techno-economics of offshore wind power in global resolution,” *Appl Energy*, vol. 393, p. 125980, 2025, doi: 10.1016/j.apenergy.2025.125980.
- [30] R. Satymov, D. Bogdanov, M. Dadashi, G. Lavidas, and C. Breyer, “Techno-economic assessment of global and regional wave energy resource potentials and profiles in hourly resolution,” *Appl Energy*, vol. 364, p. 123119, 2024, doi: 10.1016/j.apenergy.2024.123119.
- [31] D. Keiner et al., “Powering an island energy system by offshore floating technologies towards 100% renewables: A case for the Maldives,” *Appl Energy*, vol. 308, p. 118360, 2022, doi: 10.1016/j.apenergy.2021.118360.
- [32] [EC] - European Commission, “An EU Strategy to harness the potential of offshore renewable energy for a climate neutral future,” Brussels, 2020. [Online]. Available: <https://eur-lex.europa.eu/legal-content/EN/TXT/?uri=COM:2020:741:FIN&qid=1605792629666#footnoteref5>
- [33] [IRENA] - International Renewable Energy Agency, “Renewable capacity statistics 2025,” Abu Dhabi, 2025. [Online]. Available: <https://www.irena.org/Publications/2025/Mar/Renewable-capacity-statistics-2025>
- [34] Wind Europe, “Wind energy in Europe: 2024 Statistics and the outlook for 2025-2030,” Brussels, 2025. [Online]. Available:



<https://windeurope.org/intelligence-platform/product/wind-energy-in-europe-2024-statistics-and-the-outlook-for-2025-2030/>

- [35] Wind Europe, “Our energy, our future, how offshore wind will help Europe go carbon-neutral,” Brussels, 2019. [Online]. Available: <https://windeurope.org/intelligence-platform/product/our-energy-our-future/>
- [36] [Eirgrid] - Electric power transmission operator in Ireland, “Fuel Mix 2024,” Dublin, 2025. [Online]. Available: [https://www.eirgrid.ie/publications?page=1&pageSize=10&keyword=fuel+mix&sortBy=-search\\_api\\_relevance&categories=%7B%7D](https://www.eirgrid.ie/publications?page=1&pageSize=10&keyword=fuel+mix&sortBy=-search_api_relevance&categories=%7B%7D)
- [37] Government of the UK - Department for Energy Security & Net Zero, “Digest of UK Energy Statistics Annual data for UK, 2024,” London, 2025. [Online]. Available: [https://assets.publishing.service.gov.uk/media/68dbe477ef1c2f72bc1e4c4d/DUKES\\_2025\\_Chapters\\_1-7.pdf](https://assets.publishing.service.gov.uk/media/68dbe477ef1c2f72bc1e4c4d/DUKES_2025_Chapters_1-7.pdf)
- [38] The World Bank Group, “Global Wind Atlas,” Washington, D.C., 2025. [Online]. Available: <https://globalwindatlas.info/en/area/Ireland>
- [39] R. Atan, J. Goggins, and S. Nash, “A Detailed Assessment of the Wave Energy Resource at the Atlantic Marine Energy Test Site,” *Energies*, vol. 9, no. 11, p. 967, 2016, doi: 10.3390/en9110967.
- [40] Government of Ireland - Department of Enterprise - Tourism and Employment, “Offshore wind energy,” Dublin, 2024. [Online]. Available: <https://www.gov.ie/en/department-of-enterprise-tourism-and-employment/policy-information/offshore-wind-energy/>
- [41] Government of the UK - Department for Energy Security & Net Zero, “Clean Power 2030 Action Plan: A new era of clean electricity – main report,” London, 2025. [Online]. Available: <https://www.gov.uk/government/publications/clean-power-2030-action-plan/clean-power-2030-action-plan-a-new-era-of-clean-electricity-main-report>
- [42] J. AlFaraj, E. Popovici, and P. Leahy, “Solar Irradiance Database Comparison for PV System Design: A Case Study,” *Sustainability*, vol. 16, no. 15, p. 6436, 2024, doi: 10.3390/su16156436.
- [43] The World Bank Group, “Global Solar Atlas,” Washington, D.C., 2025. [Online]. Available: <https://globalsolaratlas.info/map?c=53.846046,-3.493652,6&m=site&s=53.120405,-7.77832>
- [44] Sustainable Energy Authority of Ireland, “Energy in Ireland,” Dublin, 2024. [Online]. Available: <https://www.seai.ie/sites/default/files/publications/energy-in-ireland-2024.pdf>
- [45] Government of Ireland - Department of Climate - Energy and the Environment, “Future Framework for Offshore Renewable Energy,” Dublin,



2025. [Online]. Available: [https://assets.gov.ie/static/documents/Future\\_Framework\\_for\\_Offshore\\_Renewable\\_Energy\\_\\_2025\\_Review.pdf](https://assets.gov.ie/static/documents/Future_Framework_for_Offshore_Renewable_Energy__2025_Review.pdf)
- [46] Government of the UK - House of Commons Library, "The UK's Plans and Progress to Reach Net Zero by 2050," London, 2025. [Online]. Available: <https://researchbriefings.files.parliament.uk/documents/CBP-9888/CBP-9888.pdf>
- [47] D. Keiner, L. Walter, M. ElSayed, and C. Breyer, "Impact of backtracking strategies on techno-economics of horizontal single-axis tracking solar photovoltaic power plants," *Solar Energy*, vol. 267, p. 112228, 2024, doi: 10.1016/j.solener.2023.112228.
- [48] A. von Jouanne, E. Agamloh, and A. Yokochi, "A Review of Offshore Renewable Energy for Advancing the Clean Energy Transition," *Energies*, vol. 18, no. 18, p. 4798, 2025, doi: 10.3390/en18184798.
- [49] D. Keiner, L. Walter, D. Bogdanov, I. M. Peters, and C. Breyer, "Assessing the impact of bifacial solar photovoltaics on future power systems based on capacity-density-optimised power plant yield modelling," *Solar Energy*, vol. 295, p. 113543, 2025, doi: 10.1016/j.solener.2025.113543.
- [50] C. Breyer, A. S. Oyewo, A. Kunkar, and R. Satymov, "Role of Solar Photovoltaics for a Sustainable Energy System in Puerto Rico in the Context of the Entire Caribbean Featuring the Value of Offshore Floating Systems," *IEEE J Photovolt*, vol. 13, no. 6, pp. 842–848, 2023, doi: 10.1109/JPHOTOV.2023.3319022.
- [51] Government of the UK - Chief Scientist's Group report, "State of the environment: the coastal and marine environment," London, 2023. [Online]. Available: [https://assets.publishing.service.gov.uk/media/63ce7d96d3bf7f3c40d6721f/State\\_of\\_the\\_environment\\_-\\_the\\_coastal\\_and\\_marine\\_environment\\_-\\_report.pdf](https://assets.publishing.service.gov.uk/media/63ce7d96d3bf7f3c40d6721f/State_of_the_environment_-_the_coastal_and_marine_environment_-_report.pdf)
- [52] [IEA] - International Energy Agency, "Managing Seasonal and Interannual Variability of Renewables," Paris, 2023. [Online]. Available: <https://www.iea.org/reports/managing-seasonal-and-interannual-variability-of-renewables>
- [53] S. Khalili, A. S. Oyewo, G. Lopez, K. Kaypnazarov, and C. Breyer, "Technologies, trends, and trajectories across 100% renewable energy system analyses," *Renewable and Sustainable Energy Reviews*, vol. 226, p. 116308, 2026, doi: 10.1016/j.rser.2025.116308.
- [54] S. Khalili and C. Breyer, "Review on 100% Renewable Energy System Analyses—A Bibliometric Perspective," *IEEE Access*, vol. 10, pp. 125792–125834, 2022, doi: 10.1109/ACCESS.2022.3221155.



- [55] C. Breyer, G. Lopez, D. Bogdanov, and P. Laaksonen, "The role of electricity-based hydrogen in the emerging power-to-X economy," *Int J Hydrogen Energy*, vol. 49, pp. 351–359, 2024, doi: 10.1016/j.ijhydene.2023.08.170.
- [56] S. Khalili, E. Rantanen, D. Bogdanov, and C. Breyer, "Global Transportation Demand Development with Impacts on the Energy Demand and Greenhouse Gas Emissions in a Climate-Constrained World," *Energies*, vol. 12, no. 20, p. 3870, 2019, doi: 10.3390/en12203870.
- [57] D. Bogdanov et al., "Radical transformation pathway towards sustainable electricity via evolutionary steps," *Nat Commun*, vol. 10, no. 1, p. 1077, 2019, doi: 10.1038/s41467-019-08855-1.
- [58] [EC] - European Commission. Directorate-General for Communication, "Ireland - Final updated NECP 2021-2030 (submitted in 2024)," Brussels, 2024. [Online]. Available: [https://commission.europa.eu/publications/ireland-final-updated-necp-2021-2030-submitted-2024\\_en](https://commission.europa.eu/publications/ireland-final-updated-necp-2021-2030-submitted-2024_en)
- [59] Government of the UK - Department for Energy Security and Net Zero, "Carbon Budget Delivery Plan," London, 2023. [Online]. Available: <https://www.gov.uk/government/publications/carbon-budget-delivery-plan>
- [60] M. Ram, M. Child, A. Aghahosseini, D. Bogdanov, A. Lohrmann, and C. Breyer, "A comparative analysis of electricity generation costs from renewable, fossil fuel and nuclear sources in G20 countries for the period 2015-2030," *J Clean Prod*, vol. 199, pp. 687–704, 2018, doi: 10.1016/j.jclepro.2018.07.159.
- [61] F. Präger et al., "Evaluating nuclear power's suitability for climate change mitigation: technical risks, economic implications and incompatibility with renewable energy systems," *Frontiers in Environmental Economics*, vol. 3, 2024, doi: 10.3389/frevec.2024.1242818.
- [62] L. Haywood, M. Leroutier, and R. Pietzcker, "Why investing in new nuclear plants is bad for the climate," *Joule*, vol. 7, no. 8, pp. 1675–1678, 2023, doi: 10.1016/j.joule.2023.07.006.
- [63] L. C. Cairella, H. A. Said, and E. Pasta, "On the role of wave energy in the renewable energy mix complementarity: A comparative study between Italy and Ireland," *Proceedings of the European Wave and Tidal Energy Conference*, vol. 16, 2025, doi: 10.36688/ewtec-2025-885.
- [64] S. Jin and D. Greaves, "Wave energy in the UK: Status review and future perspectives," *Renewable and Sustainable Energy Reviews*, vol. 143, p. 110932, Jun. 2021, doi: 10.1016/j.rser.2021.110932.
- [65] D. Keiner et al., "Future role of wave power in Seychelles: A structured sensitivity analysis empowered by a novel EnergyPLAN-based optimisation tool," *Energy*, vol. 303, p. 131905, 2024, doi: 10.1016/j.energy.2024.131905.



- [66] A. Kies, B. U. Schyska, and L. von Bremen, "The optimal share of wave power in a highly renewable power system on the Iberian Peninsula," *Energy Reports*, vol. 2, pp. 221–228, 2016, doi: 10.1016/j.egy.2016.09.002.
- [67] A. Gulagi et al., "Analysing techno-economic impacts of integrating wave power to achieve carbon neutrality and electricity based fuel exports: A case for New Zealand," *Energy*, vol. 319, p. 134878, 2025, doi: 10.1016/j.energy.2025.134878.
- [68] J. Subtil Lacerda and J. C. J. M. van den Bergh, "Diversity in solar photovoltaic energy: Implications for innovation and policy," *Renewable and Sustainable Energy Reviews*, vol. 54, pp. 331–340, 2016, doi: 10.1016/j.rser.2015.10.032.
- [69] J. Wang and P. D. Lund, "Review of Recent Offshore Photovoltaics Development," *Energies*, vol. 15, no. 20, p. 7462, 2022, doi: 10.3390/en15207462.

